

# WATTROUTER ECO - USER MANUAL

FOR MODELS:  
WATTROUTER ECO (WRE 01/06/14 AND WT 02/10)

HOW TO FIT AND SETUP THE DEVICE

Document version: 3.2

Last revision: 1. 4. 2024

Company: SOLAR controls s.r.o.

**TABLE OF CONTENTS**

General information.....	4
Description of basic function .....	5
Packaging contents .....	7
Safety warning .....	8
Fitting the device.....	9
Inserting the SC-Gateway or SC-Router module .....	19
Device configuration .....	20
USB driver installation.....	20
WATTconfig ECO control software installation .....	22
Setting up main function.....	22
Setting up CombiWATT mode .....	25
Setting up time schedules .....	26
FB input configuration.....	27
Wireless communication settings .....	27
S-Connect protocol settings .....	27
Finishing the configuration .....	27
Description of WATTconfig ECO items .....	28
Main window .....	28
Measured parameters and statuses .....	29
Input settings tab .....	31
Output settings tab .....	33
Time schedules tab .....	38
Other settings tab .....	41
S-Connect tab .....	45
Statistics tab.....	50
Log tab.....	51
Options and buttons .....	52
USB/COM driver configuration window.....	53
Buy additional features window .....	54
LED statuses .....	55
Configuration examples .....	56
Example No. 1 – one load only.....	56
Example No. 2 – all 6 loads, control mode - sum of all phases .....	58

---

Example No. 3 – all 6 loads, control mode - each phase independently .....	60
Example No. 4 – 5 loads, control mode - each phase independently .....	62
Description of the S-Connect protocol.....	64
Automatic pairing of stations to the access point.....	65
Manual pairing of stations to the access point .....	66
Cancel station pairing.....	67
Device pairing.....	67
Bridges to other protocols .....	68
Protocol limitations in the WATTrouter ECO .....	68
Troubleshooting .....	69
Maintenance and repairs .....	73
Technical specifications.....	74
Battery for real time backup .....	76
Recycling .....	76
Declaration of conformity .....	77

## GENERAL INFORMATION

WATTrouter ECO is a programmable controller to optimize self-consumption of energy produced by photovoltaic or wind power plant (hereinafter referred to as PV-plant). It is a smart home energy management system. After correct installation and configuration, the controller perfectly optimizes self-consumption of energy produced by your PV-plant. WATTrouter ECO consists of a current sensing module and the regulator itself.

WATTrouter ECO has the following features:

- Three-phase indirect current measurement.
- One phase detection of voltage necessary to determine the power direction on L1 and SW detection to determine the current direction on L2 and L3.
- Evaluation of active power outputs in individual phases, necessary to determine the surplus of produced electric power.
- Regulation based on the sum of power outputs (summary surplus) from all three phases or based on surplus in each phase.
- Switching up to 6 outputs (2 relays and 4 external solid state relays SSR) based on configured priorities.
- Switching up to 6 wireless outputs based on configured priorities (only with SC-Gateway module).
- Optimal use of surplus energy produced by PV-plant on SSR outputs through the application of proportional synchronous regulation of resistive loads, compliant to European standards EN 61000-3-2 and EN 61000-3-3. This regulation modulates connected load's power exactly according to the available surplus energy.
- Very short average dynamic response of the controller (up to 10 s)
- Optional CombiWATT program used for switching loads under a combined mode where energy is taken both from PV-plant and public grid (especially suitable for water heating and also for swimming pool filtering system).
- Input for low tariff signal (night/low tariff) for CombiWATT. This is for households where double tariff rates will apply.
- 1 input for connection of impulse output of external energy meter, which may measure any power output. Measured value is displayed in WATTconfig ECO application.
- Separated current sensing module and regulator for easy installation into existing household wiring.
- WATTconfig ECO software designed for MS Windows, Linux and MAC OS X provides comfortable controller configuration and monitoring via USB interface.
- Real-time module backed up with a lithium battery for advanced management of outputs and CombiWATT function.
- Time schedules for outputs.
- S-Connect protocol for sharing devices over existing network or wireless infrastructure.
- Daily, weekly, monthly and annual statistics (only with activated SW feature).
- PWM mode for outputs allowing for proportional control of suitable heat pumps, air conditioners or battery chargers (only with activated SW feature).

- Firmware updates.

## DESCRIPTION OF BASIC FUNCTION



*If the device is equipped with the SC-Router wireless module, the device operates only as a receiver and switches outputs according to the master system requirements. For more information, see chapter Inserting the SC-Router module.*

The current sensing module measures electric current in real time and on all phases. The regulator evaluates the measured electric currents and if it determines the available surplus energy produced by the PV-plant, it will switch on connected loads according to adjustable priorities, while constantly trying to maintain zero energy flow through the current sensing module, the so called "virtual zero" (the sum of active power outputs on all three phases = 0) or optionally, on each phase separately, so called "phase zero".

### **Switching according to priorities is done in the following way:**

By default (during night), all loads are turned off. If surplus energy generated by PV-plant is determined in the morning, the output with the first (highest) priority is switched on.

The switching time is different according to selected output function.

- SSR/PWM outputs (proportional outputs) are switched on almost immediately after surplus energy is detected and the controller gradually (synchronous control or PWM modulation) maintains "virtual zero" or "phase zero", according to the control settings.
- Relay outputs are switched on only if the surplus energy exceeds the preset load's nominal power. Alternatively, relay outputs may be operated in "prepend" mode if there is sufficient power at any proportional output with nearest higher priority. This allows for maximum utilization of the produced surplus power even for relay outputs - refer to the "Prepend before SSRs" function.

When load with 1st priority is fully switched on (for proportional output it means switching on the maximum power), the system waits until the power output of PV-plant increases again (beginning of dawn). If electric production is determined even when this load is switched on, load with second priority in the same mode is switched on as well.

If the power output of PV-plant is still increasing, additional connected loads are switched on in the same mode.

If the power output of the PV-plant decreases, or if another load - not connected to the WATTrouter device is switched on, the switched (active) outputs are disconnected - again according to preset priorities but in reverse order (the load with lower priority is disconnected first).

For relay outputs there may be set a minimum switch on time. If, simultaneously with a relay output the proportional output with higher priority is switched on, and the available surplus energy is reduced, the proportional output will try to reduce the power output of the load (even down to zero) in order to maintain virtual zero or phase zero on the current sensing module, if possible.

Except for the situation specified in the paragraph above, the controller never violates the established priorities.

The above specified principle applies only to standard connection of the current sensing module, connected right behind the facility's main energy meter, so the WATTrouter device uses only the actual PV-plant surpluses (recommended settings). However, WATTrouter controller is versatile device and can be connected according to your needs. For example you can place the current sensing module just next to the PV inverter and then you can maintain the virtual or phase zero on that line.

The above specified basic control mode may be combined with another mode of output switching, provided that low tariff signal (double tariff rate) is available (CombiWATT mode), or with switching based on preset time conditions (time schedules).



*This device is not designed for precise active power measurement (it is not a replacement for a wattmeter). Active power is measured with sufficient precision in order to maintain all control functions.*

## PACKAGING CONTENTS

Contents of packaging:

1 WATTrouter ECO regulator

1 WATTrouter ECO current sensing module

1 USB cable

1 short manual with links to this manual, software and firmware updates

**SAFETY WARNING**

**When you receive your package, inspect the packaging unit for damages. After opening your package, inspect the regulator and the current sensing module for damages. Do not fit the regulator or the current sensing module if you see signs of mechanical damages!**



**Always have the regulator and the current sensing module fitted by a person with the necessary electrical qualification. It is necessary that you read this manual thoroughly and observe all safety warnings and requirements specified herein.**



**The regulator and the current sensing module must be fitted in a dry room without excessive dust level. The room must be protected from direct sunlight and the ambient temperature must be maintained within the range mentioned in chapter Technical specifications below. Do not place the regulator or system electronic components near flammable objects!**



**When power SSRs are connected to SSR outputs, it is absolutely necessary to fit these into a distribution box equipped with adequate heat dissipation system (with ventilation grid or vents)!**



**Make sure that unauthorized persons, mainly children, cannot access the location where the controller is fitted. There is a serious risk of electric shock!**



**Only connect outputs of the controller to electrical loads which have been designed for this operation mode and for which the manufacturer does not explicitly prohibit connection via switching element!**



**The manufacturer is not liable for any damages occurred due to improper fitting or operation of the device! The owner is fully responsible for operation of the entire system.**



## FITTING THE DEVICE

WATTrouter ECO regulator may be fitted in a regular distribution board onto a 35 mm DIN rail or attached to a wall using 2 screws with round or countersink head and with diameter up to 6 mm.

WATTrouter ECO current sensing module may be fitted in a regular distribution board onto a 35 mm DIN rail.

If CYKY or other thick and hard cables cannot pass through current transformers easily, use flexible cables to extend the existing connections. When fitting the current sensing module do not press hard on it. You may damage the module.

**Tip:** Individual phase wires may pass through the current sensing module from either direction. The direction of currents may be configured in the control software.

To connect power supply to the regulator (L and N) use wires with a minimum cross-section of 0.5 mm<sup>2</sup>, for example CYKY 1.5.

To connect loads to the relay outputs use wires with adequate cross-section corresponding with the power ratings of the connected loads.

To connect loads to the power SSRs again use wires with adequate cross-section corresponding with the power ratings of the connected loads.

To interconnect the current sensing module and regulator (inputs GND and ILx) use 4-wire cable with cross-section from 0.5 to 1.5 mm<sup>2</sup>. If these wires are longer than 2m or are placed in a cable tray together with other power cables/wires, we recommend using a shielded cable.

To interconnect power SSR control inputs and/or 0-10VDC control signals with SSR outputs use wires with cross-section from 0.5 to 1.5 mm<sup>2</sup>. If these wires are longer than 2m or are placed in a cable tray together with other power cables/wires, we recommend using a shielded cable.

To interconnect S0 impulse signals from external energy meters with FB input use 2-wire cable with cross-section from 0.5 to 1.5 mm<sup>2</sup>, connected between S+ and FB terminals. If these wires are longer than 2m or are placed in a cable tray together with other power cables/wires, we recommend using a shielded cable.

Connect shielding of all shielded cables to the GND terminal as close as possible to the regulator.

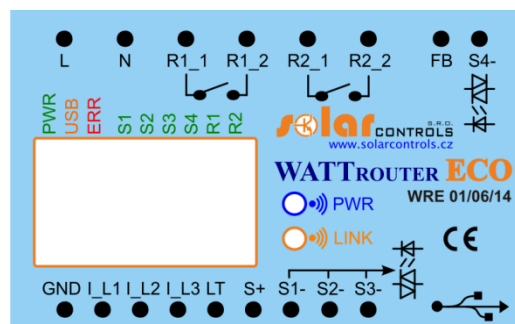

Figure 1: Connector and LED description (top view).

Regulator terminals - description:

- L – regulator power supply and voltage detection L1, 230VAC/50Hz (must always be connected)
- N – neutral wire (must always be connected)
- R1\_1 – relay output 1 – terminal 1
- R1\_2 – relay output 1 – terminal 2
- R2\_1 – relay output 2 – terminal 1

- R2\_2 – relay output 2 – terminal 2
- FB – input for connection of impulse output of external energy meter (0V or +5V)
- S4- – external output for SSR 4 – negative electrode (open collector)
- GND – common wire coming from the current sensing module (must always be connected)
- I\_L1 – electric current measuring input L1 from the current sensing module (must always be connected)
- I\_L2 – electric current measuring input L2 from the current sensing module
- I\_L3 – electric current measuring input L3 from the current sensing module
- LT – low tariff signal detection (0V or +5V)
- S+ – external output for SSR – common positive electrode (+5V)
- S1- – external output for SSR 1 – negative electrode (open collector)
- S2- – external output for SSR 2 – negative electrode (open collector)
- S3- – external output for SSR 3 – negative electrode (open collector)
- USB – USB interface connector (USB B)

#### LED description:

- PWR – regulator power on light (green)
- COM – communication light - USB interface (yellow)
- ERR – error status light (red)
- S1 – external output for SSR 1 - activity indication light
- S2 – external output for SSR 2 - activity indication light
- S3 – external output for SSR 3 - activity indication light
- S4 – external output for SSR 4 - activity indication light
- R1 – relay output No. 1 - activity indication light
- R2 – relay output No. 2 - activity indication light
- Wireless PWR – LED indicator of SC-Gateway (optional accessories)
- Wireless LINK – LED indicator of SC-Gateway (optional accessories)

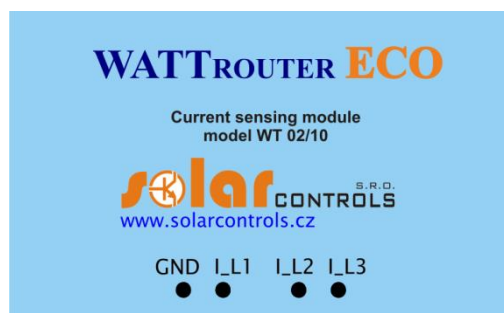

- **Figure 2: Terminals description of sensing module (top view).**

#### Current sensing module terminal description:

- I\_L1 – current measuring output L1 (must be always connected)
- I\_L2 – current measuring output L2
- I\_L3 – current measuring output L3
- GND – common wire (must always be connected)

Connect the controller according to sample connection diagrams shown lower on figures. If you observe basic principles, connections may be combined in various ways. You may connect any number of loads to any outputs. In certain cases you may remove certain phase cable from the measuring, etc.

If CYKY or other thick and hard cables cannot pass through current transformers easily, use flexible cables to extend the existing connections. When fitting the current sensing module do not press hard on it. You may damage the module.

**Tip:** Individual phase wires may pass through the current sensing module from either direction. The direction of currents may be configured in the control software.

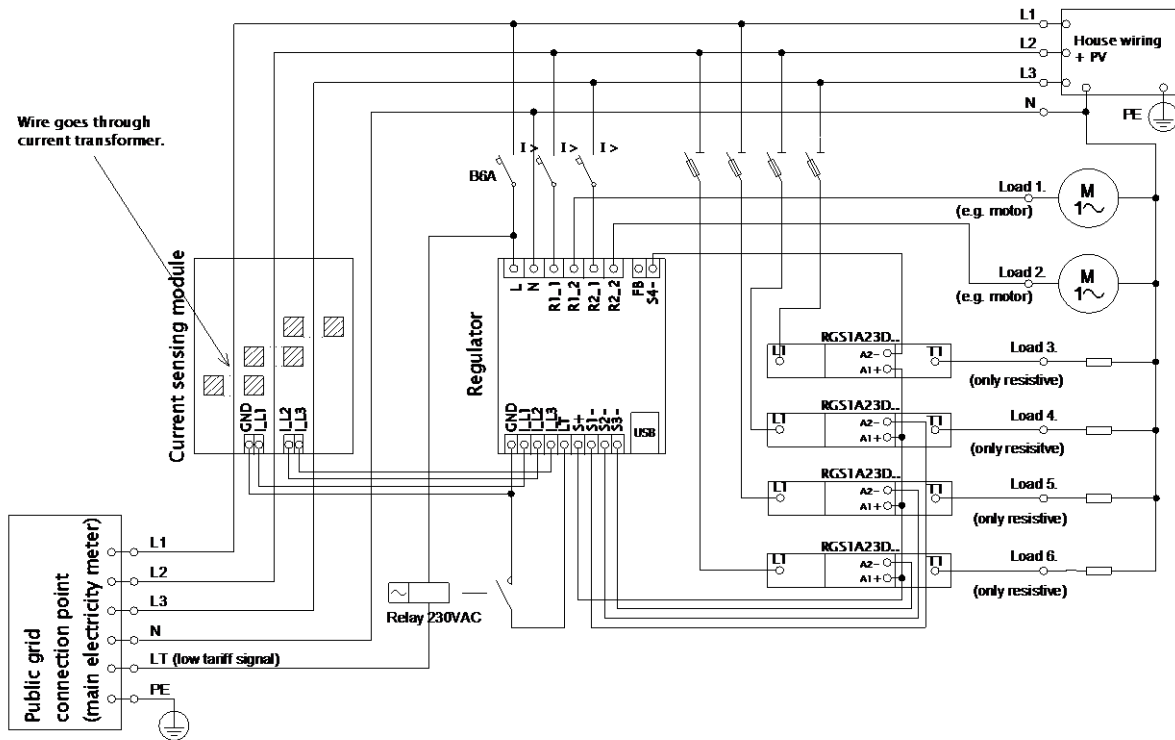

Figure 3: Three-phase connection with low tariff signal circuit for CombiWATT mode. Current sensing module is placed at the facility's supply cable coming from the distribution box where main energy meter is located. The connected loads use only real surpluses produced by PV-plant. All 6 loads are connected, 4 of them through the recommended SSRs RGC(S)1A manufactured by Carlo Gavazzi.

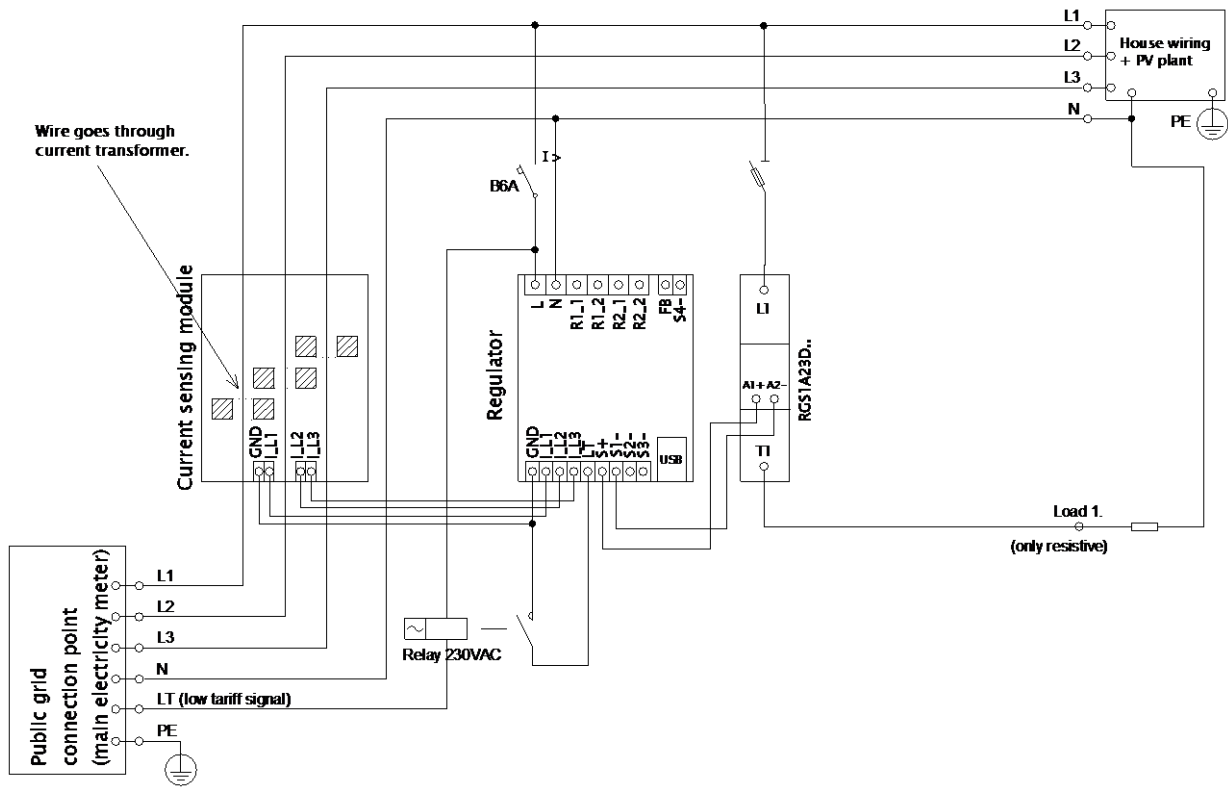

Figure 4: Three-phase connection with low tariff signal circuit for CombiWATT mode. Current sensing module is placed at the facility's supply cable coming from the distribution box where main energy meter is located. The connected loads use only real surpluses produced by PV-plant. This connection is one of the easiest – only one load (typically boiler or immersion heater) through the recommended SSR RGC(S)1A manufactured by Carlo Gavazzi.

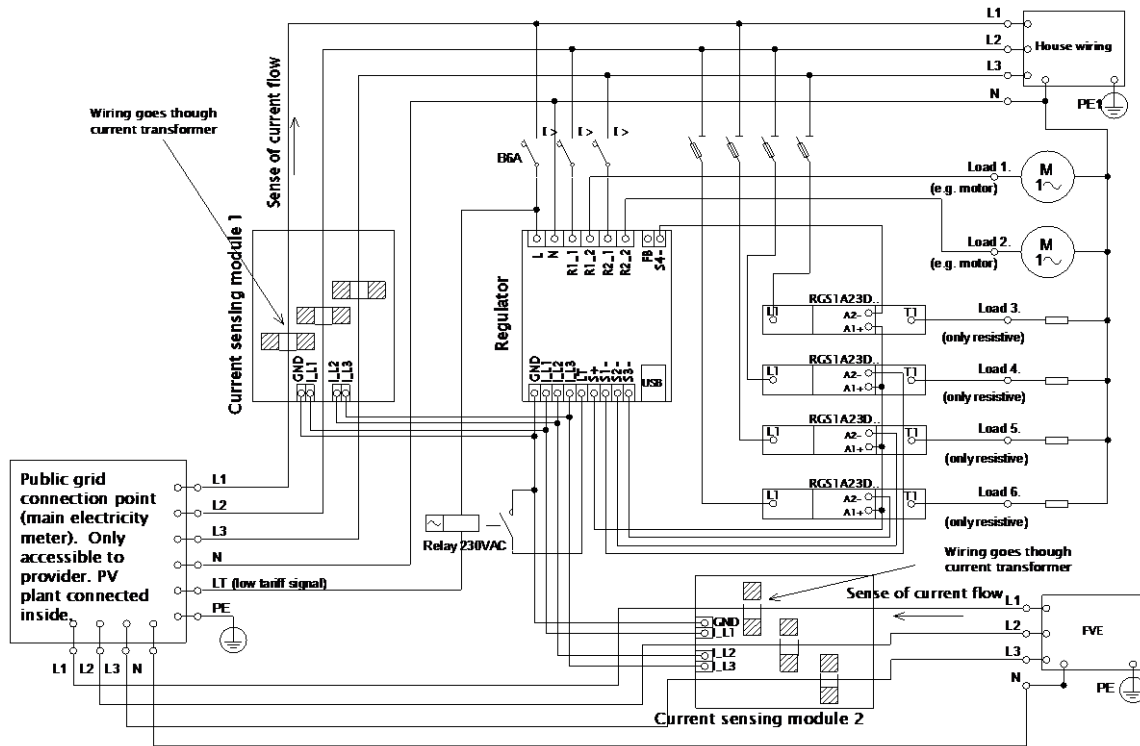

Figure 5: Three-phase connection with 2 current sensing modules and with low tariff signal circuit for CombiWATT mode. Here are connected all 6 loads, where 4 loads are over SSR through the recommended SSRs RGC(S)1A manufactured by Carlo Gavazzi. This connection is necessary if the PV-plant output is connected directly to a sealed distribution box, accessible only to the electricity provider. This may be the case for PV-plants made originally only for feed-in tariff, without self-consumption possibility. Current sensing module 1 is connected to the household wiring branch; current sensing module 2 is connected to PV-plant branch. The accuracy of measurement is reduced down to  $\pm 10\%$  in this connection because of the finite impedance of current transformer secondary winding. **Caution: Current flow through current sensing modules must always be subtracted in this connection (marked with arrows on the picture). The same phase sequence must be observed in the regulator and in both current sensing modules!**

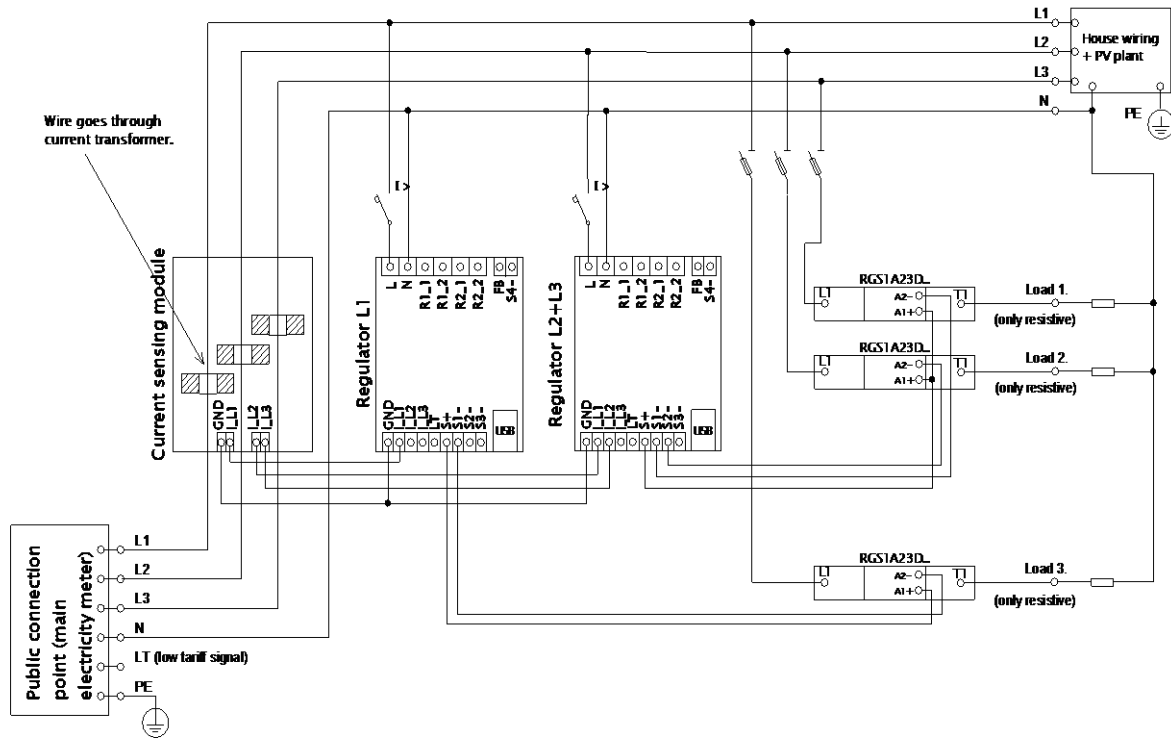

Figure 6: Three-phase connection of WATTrouter ECO with 2 regulators and without low tariff signal circuit (CombiWATT mode cannot be used). Using this connection you may extend the number of outputs up to 12. Current sensing module is placed at the facility's supply cable coming from the distribution box where main energy meter is located. Connected loads use only the actual surpluses produced by PV-plant. To make things simple, only 3 resistive (heating) loads are connected, but you may use all 12 outputs. Similarly, you may also connect 3 regulators to 1 current sensing module. In such scenario, each regulator works on one phase and you will get 18 outputs.

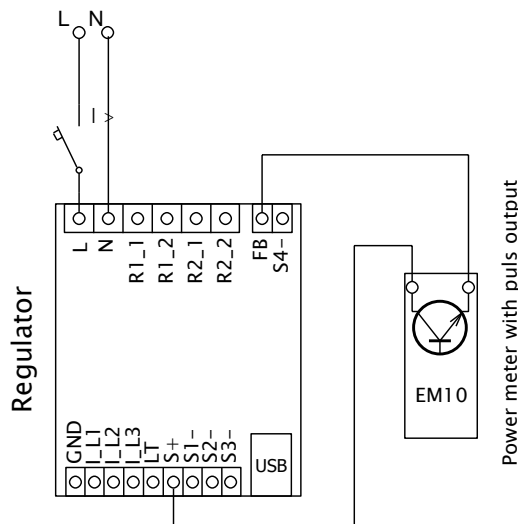

Figure 7: Connection of energy meter with pulse output S0 with input FB. On picture is type EM10 manufactured by Carlo Gavazzi.

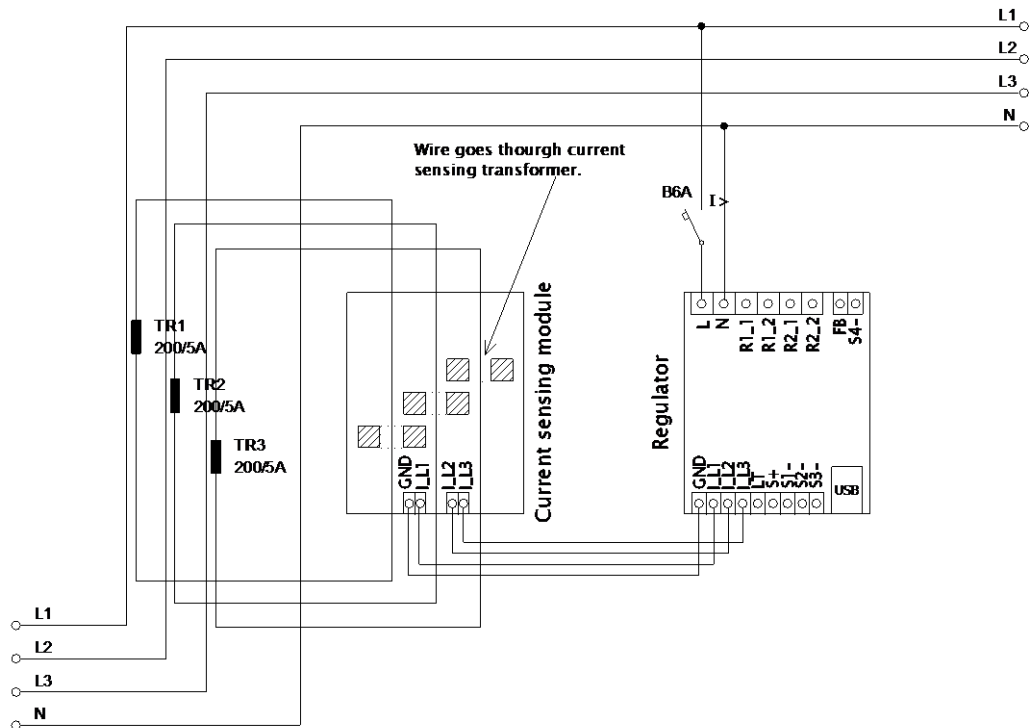

Figure 8: Increasing of current measurement range of the device for facilities where main circuit breaker is larger than 3x40A. Transformers 200/5A, or even 400/5A may be used, based on the main circuit breaker value. Secondary coil of current transformers is shorted through the current sensing module (the secondary circuit passes through measuring transformers in the current sensing module). Additional increase of current measurement range may be done if you take the secondary circuit of the current transformer and make several turns through the measuring transformer in the current sensing module (for transformers 200/5A, the best option is to make 4 turns in order to reach optimum transfer ratio 200/20A). For this purpose we recommend using lines, which are not overrated for the nominal secondary current, just to be able to make more turns through the hole of measuring transformer. When WATTrouter connected through external current transformers, the conversion ratio must be set correctly in the control software - see the item Conversion ratio of external CT's in the main window of the WATTconfig ECO software.

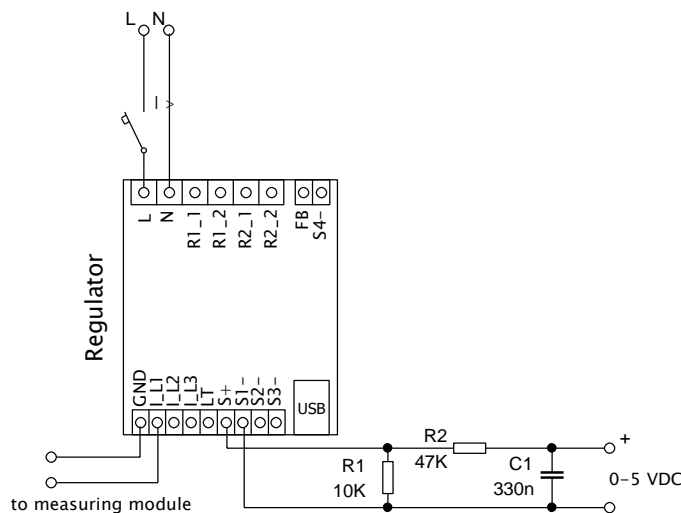

Figure 4: Connection of external devices controlled with a voltage of 0-5 VDC. The SSR output has to be operated in PWM mode. PWM signal is presented on terminal S1-(for output S2 on terminal S2- etc.). The filter element (R2 and C1) produces DC voltage with typical residual ripple about 300 mV. If you need inverted signal then connect the filter element between the S1- and GND terminals. The resistor R1 must always be connected between the S+ and Sx- terminals because the Sx- terminals have only open collector drive with a very weak internal pull-up resistor. The connected device must have a corresponding control input with sufficiently high input

impedance (which should not be below 200 kΩ); otherwise active filter could be necessary. Active filter must be always used, when the external device awaits another voltage (e.g. 0-10 VDC) or current loop (4-20 mA).

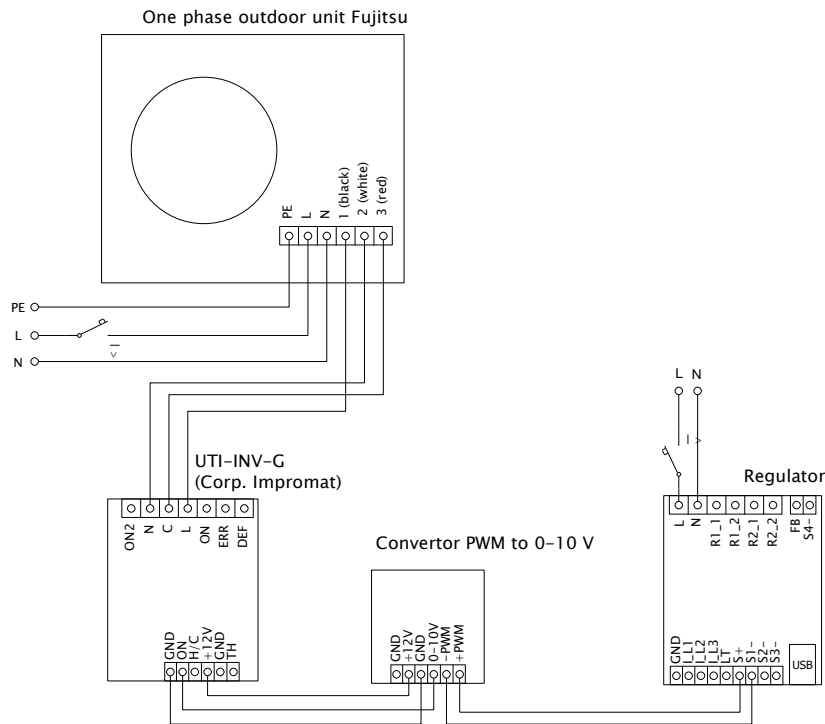

Figure 10: Connection of air conditioner or heat pump unit in mode of continuous regulation based on surplus energy. Here is listed example of outdoor unit Fujitsu controlled by module UTI-INV-G. Because this device is controlled by 0-10V, it is necessary to use a converter of PWM to 0-10V signal. For more about connection of heat pumps, see web pages of the manufacturer.



The controller may be connected only to 230VAC, 50 Hz public electric grids. Regulator must be protected with a circuit breaker - recommended rating is B6A - and connected loads must also be adequately protected! Installation may only be done when the facility's main circuit breaker is turned off!



Upon completion of the installation process make sure to check thoroughly the connection of the regulator and the current sensing module. Also check connection of terminals GND, I\_L1, I\_L2, I\_L3, LT, S+, S1-, S2-, S3-, that means all terminals located at the lower section of the regulator. **NO** power grid voltage or voltage outside of tolerances specified in the chapter Technical specifications may be connected to these terminals! Same has to be applied for terminals FB and S4- located in right top corner of controller. **NO** other than resistive (heating) loads may be connected to SSR outputs! Regular relays **CANNOT** be connected to SSR outputs! It is prohibited to connect loads with higher than the maximum allowed nominal power! If you fail to observe this rule it is almost guaranteed that you will damage the regulator and lose your warranty!



For the correct operation of the controller, it is absolutely necessary to ensure proper phasing of the measured currents with the internal voltage detector. This can be done by selecting the appropriate phase in the Input Settings tab. It is strongly recommended to connect the controller so that the phase conductor fed to terminal L1 corresponds to the phase conductor wired through the measuring transformer corresponding to the IL1 input, which will allow the measurement to match the default settings of the controller (and therefore the same as required



for older models). The IL2 and IL3 current inputs can be connected arbitrarily; the respective phases for these inputs must be set up correctly in the WATTconfig control software.



We strongly advise you to protect your loads connected to the power SSRs with fuses suitable for protection of semiconductors, rather than regular circuit breakers. Please note that SSRs damaged by overcurrent or short-circuit most likely cannot be claimed under warranty. Make sure that solid state relays are correctly connected, as required by their user manual.



No electronic devices (various measuring and protective elements, such as sub-meters and residual current circuit breakers) may be installed between the SSRs and the appliance, since they may be damaged by impulse power! Always install these devices on the line between the fuse and the solid-state relay where constant power is available.



If your facility is located in an area with higher risk of overvoltage spikes due to atmospheric discharge (lightning), we strongly recommend fitting a suitable overvoltage/lightning protection between the distribution box with the main energy meter and the current sensing module!



The current sensing module supplied with the WATTrouter Mx controller is fully compatible with the current sensing module supplied with following types: WATTrouter CWx, WATTrouter CWx SSR, WATTrouter M SSR, WATTrouter Mx, and vice versa. The current sensing module installed with these controllers can be used with the WATTrouter ECO controller (and vice versa).



If the regulator is constantly connected to PC via USB interface (mostly if long cable is used), we strongly recommend using an USB isolator!

**Note:** It is allowed to connect only pure resistive loads to SSR outputs. These loads cannot be fitted with own electronic control system nor with built-in motors (e.g. fans - see the note below). These loads may only have regular mechanically controlled thermostats and indication LEDs or neon lamps. Almost any regularly produced boilers, immersion heaters, infrared radiators, heating floor pads, motor-free dryers (infra dryer), oil heaters, cartridge heaters in a solar tanks, etc. may be used.

**Note:** Each SSR output is capable of providing power to heating loads with built-in fan for longer time (such as hair dryer, heat radiator). These loads are fitted with a built-in thermal protection, which, if synchronous SSR control mode is used for that load, will disconnect the load for low power of SSR output (in this scenario, the built-in fan's power is not sufficient to cool down the heating element of the load). Therefore, consider fitting these loads to SSR outputs carefully.

**Note:** Heating loads connected via residual-current circuit breaker may be connected to SSR outputs.

**Note:** Heating loads with nominal power up to 2.3 kW may be connected to relay outputs directly, without using external contactor.

Pulse output from external energy meters may be connected to FB input. You may also use energy meters whose pulse outputs are fitted with optically isolated switch or an optocoupler with open collector. These energy meters may measure any power outputs. Measured values are displayed in the control software WATTconfig ECO. For example, these inputs may be used to connect energy meters which measure the actual net production of PV-plant. This net production cannot generally be determined by the current sensing module.

Carefully examine connection of the controller and then turn off all circuit breakers and deactivate fuse switches for SSR outputs. Then turn on the main circuit breaker and the regulator circuit breaker (L1 power supply). The LED PWR lights up (power on indication). If the light is off, or if it does not shine permanently, or if

the LED ERR starts to flash (error status), proceed according to instructions specified in the Troubleshooting chapter. In default status no output is active and therefore, no load will be turned on.

Now the controller is fitted and ready for configuration.

## INSERTING THE SC-GATEWAY OR SC-ROUTER MODULE

Insert the module to sockets in the regulator according to the images below. Before insertion you must lift the regulator cover with a small screwdriver or similar tool.



**Make sure the regulator is turned off before inserting the module!**



**Keep the proper orientation of the module. Reverse orientation can damage the module!  
Insert the module gently, without unusual force!**

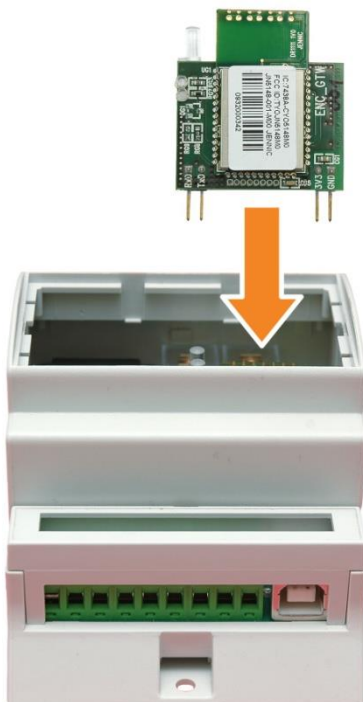

Figure 5: Insert the module to sockets on regulator mainboard, use vertical movement as the arrow indicates.

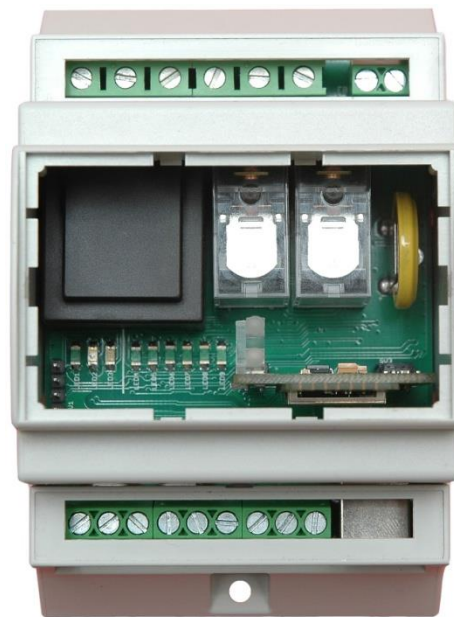

Figure 6: Resulting position of the module inside the regulator.

After regulator power on, the blue LED on the module must indicate the module initialization sequence, refer to chapter LED Statuses. In case that does not happen, refer to chapter Troubleshooting.

The SC-Router module can be inserted in the same way.

## DEVICE CONFIGURATION

You will need notebook or regular PC (placed closely enough to the regulator) with USB interface (hereinafter referred to as a computer only). The controller is configured using the WATTconfig ECO control software. The installation package for this software is available on manufacturer's web pages. Before installing the WATTconfig ECO control software you need to install the driver for USB interface.



**In order to connect to the USB interface, it is necessary - due to safety reasons - to turn off the entire distribution box before manipulation.**

If you cannot continue with the settings (due to any reasons), proceed according to instructions specified in the Troubleshooting chapter.

## USB DRIVER INSTALLATION

The installation procedure is described for Windows XP, English locale. The procedure is similar for newer systems, or it is much simpler. Newer versions of operating systems (Windows, Linux, MAC OS) usually already have these drivers pre-installed so you can skip reading further paragraphs.

1. Insert the attached USB cable to the USB connector of the regulator and then to the computer.
2. Turn on the controller. The green LED PWR must light up (power on indication). Also the yellow LED COM light will or should flash briefly (communication process indication) as the USB device will start to register in your computer.
3. After a moment, following window must appear confirming that a new device was found:

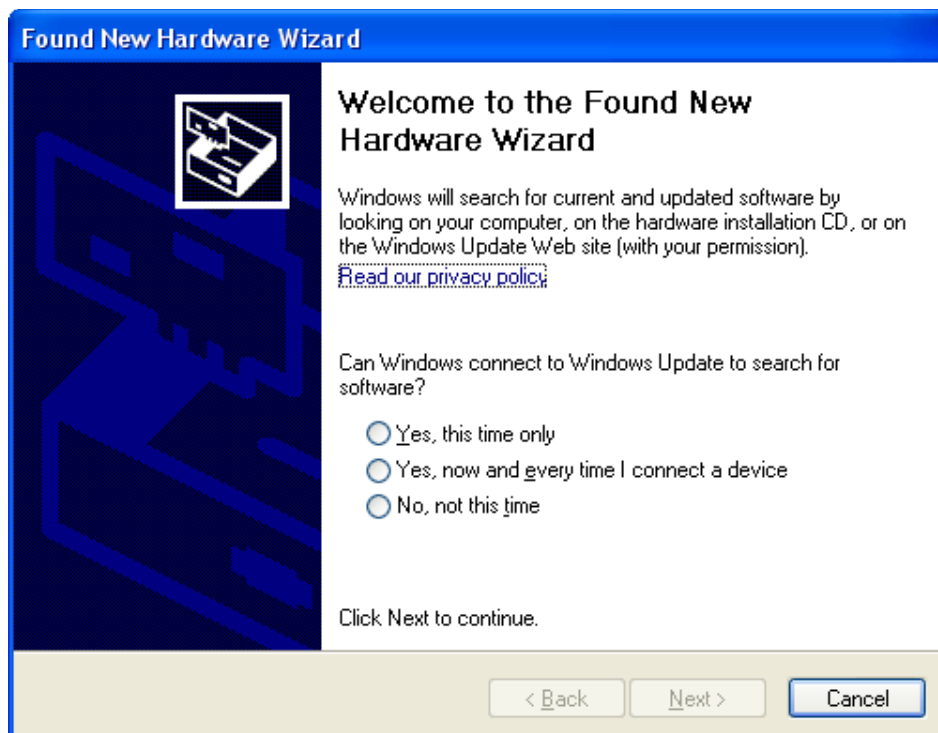

4. Select: No, not this time. In the following window select: Install from a list or specific location (Advanced).

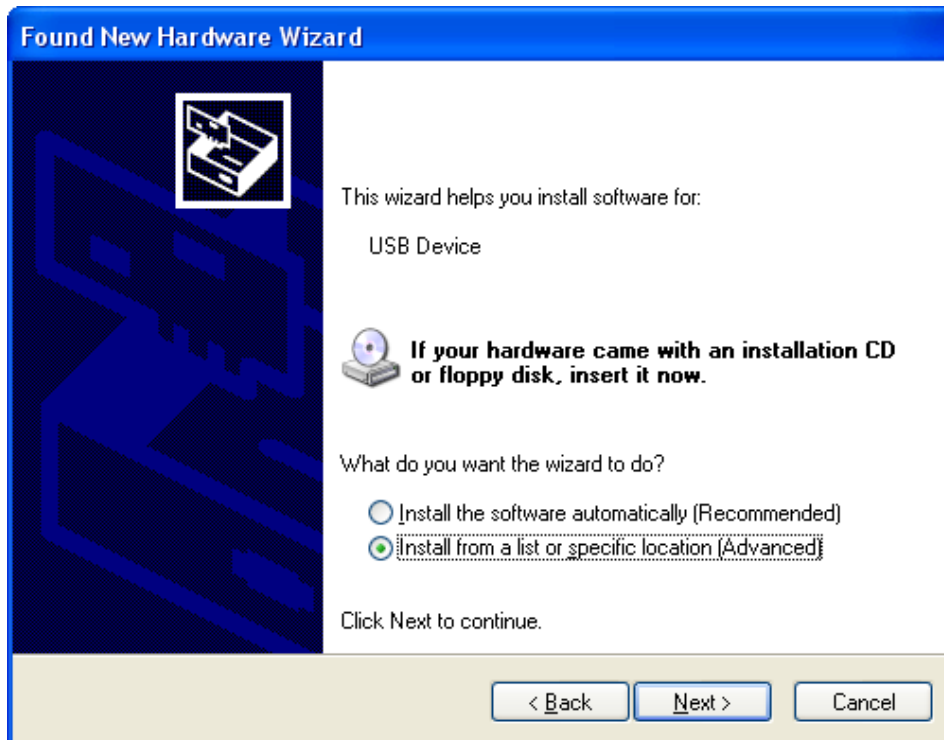

5. Select the path to the driver file:

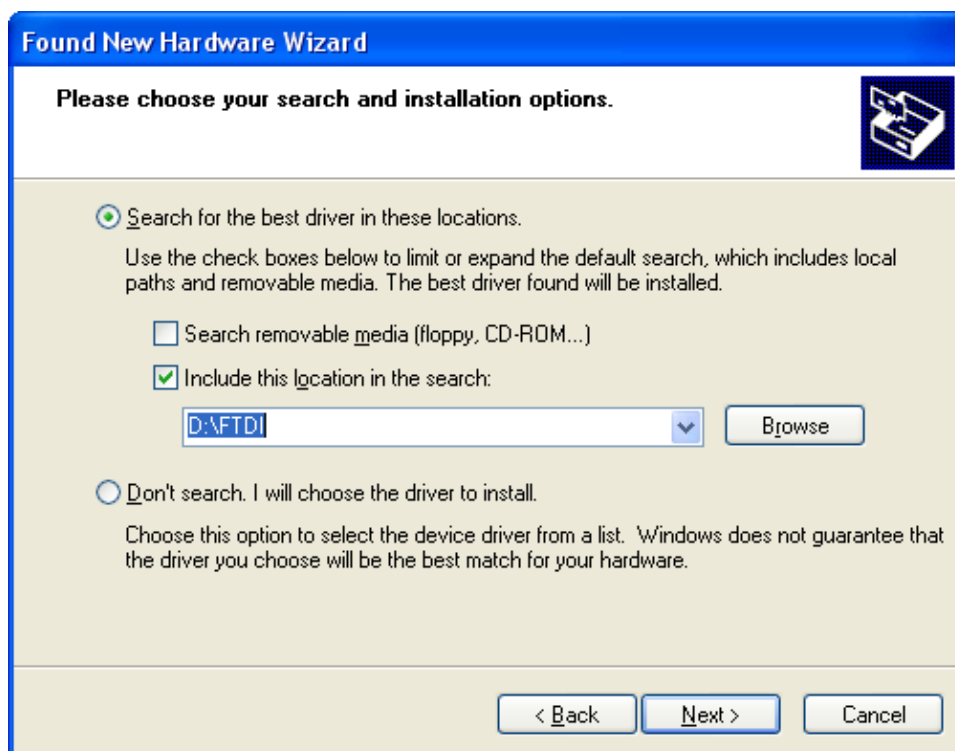

6. If the driver has been installed successfully, this window appears:



7. During the installation there might appear a warning about an invalid digital driver signature. Just ignore it. The device is registered in your system device manager as USB serial converter (menu Universal Serial Bus Controllers)
8. You must perform the same installation process for the second USB serial port device.

#### WATTCONFIG ECO CONTROL SOFTWARE INSTALLATION

1. Turn on the PC.
2. Run WATTconfig\_ECO\_Setup\_x86\_64.exe which you may download from manufacturer's web pages.
3. Follow the on-screen instructions.

#### SETTING UP MAIN FUNCTION

1. Click on START button in your PC and run the WATTconfig ECO control software. The system will display the main software window.
2. Make sure that the controller is turned on and connected to your computer. Make sure that USB interface driver is correctly installed.
3. Select correct port for connection. This can be done in the dropdown menu Port in Serial port driver configuration window, which will show up by clicking on button Configure connection.
4. Click on the Connect button. The controller should be connected now and the connection indicator (a stripe) should be displayed in green. If it is not, and the system displays an error message, wait until the USB driver is ready for use in your PC or inspect the settings in USB/COM port driver configuration window. This window will be displayed by pressing Configure connection button.
5. After establishing successful communication, you should be able to see the current measured values (power outputs on individual phases, etc.). No outputs should be active ("unused" priority). Also no time schedules should be used.

6. Now you can configure measuring inputs. This can be done on the "Input settings" tab. First, you set the phase sequence and then the direction of current flows through the current sensing module.
- a. **Setting up phase sequence:** Turn off the PV-plant and turn on a resistive load on each phase which will be involved in the measuring process. The system will display measured active power on each individual phase. For now, you may ignore the signs of the measured power values. Now, in the Phase field select corresponding phase, based on the actual status recognized by the controller, and press Write button. The configuration will be saved in the controller. If the output values measured on individual phases differ too much from the reality, change the phase for given input and again press the Write button. Repeat these steps for all 3 inputs IL1, IL2 and IL3 until all measured powers are displayed correctly.
  - b. **Setting up the direction of current flows through the current sensing module:** As specified in the previous step, leave loads on measured phases switched on. When the PV-plant is turned off, **all measured power output values must be smaller than 0 or equal to 0**. If any of the measured power outputs is positive it means that the phase wire is passing through the current sensing module in a reverse direction. Use the Current orientation field for the relevant phase, select the reversed option and press the Write button. The configuration will be saved in the controller. Now, all measured power outputs must be  $\leq 0$ . Turn the PV-plant on and turn off all loads. **Now, measured outputs must be positive ( $\geq 0$ )**. If they are not, or if the measured values do not correspond with nominal power ratings of the connected loads, or if they do not correspond with the power output of the PV-plant, you have either still connected another loads (which you don't know about, such as various loads in stand-by mode, etc.), or the phase sequence in voltage or in current inputs does not match, or you may have a defect in household wiring. **In any case, make sure to inspect the entire electric wiring.**
  - c. You can verify the correctness of measurement input configuration by using the chart "Input checking oscilloscope". This chart shows measured current waveforms in selected phase, values are given in units of the built-in A/D-converter (digits), these are not normalized to amps due to performance. This feature should only aid the fitter when configuring the measuring inputs. **Always verify with a resistive (heat) load only, so that the phase shift between voltage and current is zero ( $\cos(\varphi) = 1$ )! Moreover, in order to verify the measuring inputs the amplitude of current half-wave should always be greater than 1000 digits** (to be sure about the correctness of the settings).

*Note: During normal operation there may be shown even "exotic" waveforms. Be sure this is the real current flowing through the phase wire, a superposition of currents flowing through the connected appliances which are not sinusoidal or their power factor varies from one.*

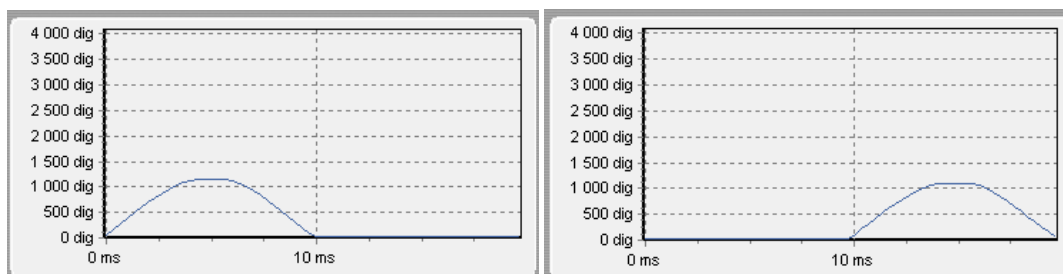

Figure71: Input is fitted correctly - sine wave of the current flowing through a resistive (heat) load is in phase with the voltage. WATTconfig ECO shows negative values on selected phase (consumption). Left image appears when there is normal (default) current flow direction, right image appears for opposite direction. Note: The PV-inverter throughput appears exactly as the opposite, because the current is anti-phased with the voltage. If the inverter performs power factor compensation you can observe corresponding phase shifts.

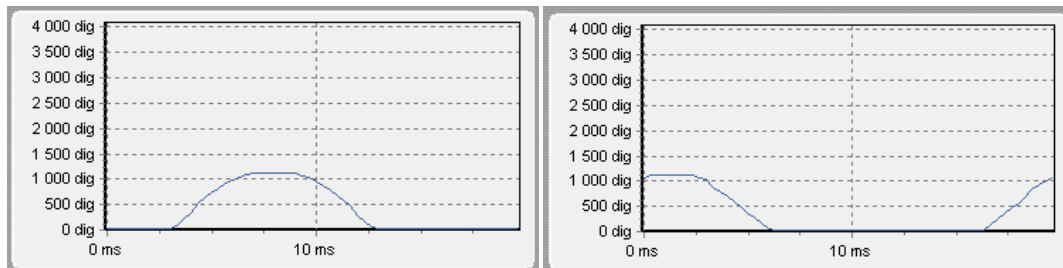

Figure 82: Input is fitted incorrectly - sine wave of the current flowing through a resistive (heat) load is not in phase with the voltage and either precedes (left image) or lags behind (right image) the voltage by 1/3 of mains half-wave. Measuring inputs are fitted incorrectly and you need to select correct option in the Phase field for respective input.

7. After a successful setup of measuring inputs you may begin to test outputs. This can be done on the "Output settings" tab. Each connected load must be tested separately. Turn on circuit breaker or activate fuse switch for the first output, and press the TEST button for the corresponding output. The load should switch on. Further, when the load is switched on, the active power drawn by connected load must be detected by the current sensing module on the relevant phase.
8. After you have successfully tested all outputs, you may begin to configure the control mode in the Control settings field. This can be done on the "Other settings" tab. Set this mode either to "sum of all phases" or to "each phase independently", based on the configuration of your 4-quadrant energy meter. If you are not sure how your energy meter is configured, please contact your electricity provider or use the "each phase independently"-mode, which works for any configuration of the energy meter.

In order to use the "each phase independently"-mode, it is necessary to select correct phase for each output, i.e. phase where the corresponding load is really connected. Controller will then try to maintain zero energy flow in each phase ("phase zero"). You may check correct phase assignment again through the TEST button. Within a short time after pressing the button the active power drawn by connected load must be detected by the current sensing module on relevant phase.

As far as your energy meter is configured to evaluate sum of powers in all phases, you may use the mode "sum of all phases". Here the controller will try to maintain virtual zero energy flow. This means that for output switching it takes the sum of measured powers from all 3 phases ("virtual zero"). Here you may try experimenting with both methods, but it is recommended to use "sum of all phases"-mode, because it is more effective for the user.

9. After a correct setup of the control mode, you may start to assign priorities and power ratings for individual outputs. This can be done on the "Output settings" tab. Select priorities of individual loads. The switching process based on priorities may be described as follows:

By default (during night), all loads are turned off. If PV-plant production (available surplus energy) is determined in the morning, the output with the first (highest) priority is switched on. The switching time is different for proportional outputs (their function equals to proportional or PWM) and relay outputs. Proportional outputs are switched on almost immediately (this is the proportional switching), but relay outputs are switched on only if the available surplus energy exceeds the value specified in the Connected power field (there is also a different solution available – see the "Prepend before SSRs" function). When the load is switched on (for proportional output it means the load is switched to the value specified in the Maximum power field), the system waits until the power output of PV-plant increases again (sunrise). If additional available surplus energy is determined when the load with first priority is switched on, then load with second priority is switched on in the same mode. The same applies to all outputs. If the available surplus energy decreases, or if another load in the household is



switched on, active outputs are disconnected according to preset priorities but in reverse order (first, the load with the lowest priority gets disconnected).

The value in the "Connected power" field should be equal to the power rating of the connected load. For relay output it must be higher or equal to the power rating of the load, otherwise the controller will not operate correctly, and the load will be repeatedly turned on and off. For proportional output this value only configures the control dynamics, but it should be also equal to the actual power rating of the load.

The fields On-delay time and Off-delay time for relay outputs specify the time delay to switch the relay on or off after a condition has been detected to do so. This feature is necessary for loads which cannot be switched on frequently.

Set outputs according to the connected loads and based on your priorities and then press the Write button. The configuration will be saved in the controller. Now the main function of the controller should be configured.

10. Test the main function of the controller, or possibly, modify priorities for outputs and power settings of connected loads.

## SETTING UP COMBIWATT MODE

After you have successfully tested the main function, you may start to configure CombiWATT mode, provided a low tariff signal is connected to the controller (it may be used even if single tariff rate is present – see notes below). This can be done on the "Output settings" tab. CombiWATT mode provides constant daily energy supply to the connected loads. This mode is indispensable if you need to heat up water but also e. g. if you use a swimming pool filtering system during cloudy days or when your PV-plant is temporarily out of order. In CombiWATT mode, energy is taken both from PV-plant and from public grid.

Determine the optimal value of energy in kWh for the connected load (for example for a boiler or immersion heater), which you plan to supply the load with every day. For example, for a boiler it is suitable to determine the value of electric energy based on the average consumption of warm water. Usually, electric energy

$$E[kWh] = \frac{c_v * V[l] * \Delta T[K]}{3600000}$$

necessary to increase the temperature of water by 40°C equals to: . If you enter it into the formula you will get:  $E[kWh] = 0.0464 * V[l]$ . For a 180 liter boiler it will be 8.36 kWh. We recommend to increase this value by the daily heat loss of the boiler and also to modify (reduce) the value based on the actual average consumption of warm water.

**Note:** *If you are heating water for example, the controller does not "know" how hot the water in the boiler is and therefore, the assumed values of the supplied electric energy may be higher than the actual delivered energy (the boiler thermostat may shut it off at any time).*

Mark the CombiWATT field for the relevant output (output must be activated, which means that the output must be assigned with the relevant priority), enter the established value of the daily electric energy in kWh and press the Write button. The configuration will be saved in the controller.

**The CombiWATT mode is activated only if ALL the following conditions are met:**

- a. The output is activated (priority has been assigned to the output - that means the output is not in the "not used" status).
- b. PV-plant does not produce electric power (active powers at all measured phases are  $\leq$  (less than or equal to the) CombiWATT production limit field).

- c. During the day, PV-plant did not supply the load with the required amount of energy, that is, the field "Assumed supplied energy" is lower than the value specified in the "CombiWATT [kWh]" field for the relevant output.
- d. Low tariff signal has been detected (the information field "low tariff" is red). Energy from public grid is always consumed in CombiWATT only if low tariff is present. See note below to learn how to configure this mode if you don't have double tariff rate.
- e. The "Time to activate CombiWATT"-field shows zero.

**The CombiWATT mode is deactivated if some of the following conditions will apply:**

- a. The value in the field "Assumed supplied energy" reached the "CombiWATT [kWh]" value for the relevant output.
- b. Production has been detected at some of the measured phases (active power at some measured phase is > (greater than the) CombiWATT production limit field).
- c. The low tariff signal is turned off.

**Reset of energy counters (that is reset of values in the fields "Assumed supplied energy")**

- a. At sunrise. Counters are reset to zero at sunrise time, which is automatically calculated by the controller.
- b. At fixed time. Counters are reset to zero at a preset time.

More information about counter reset processing is available in the chapter Description.

**Note:** For boilers or any other warm water tanks the CombiWATT mode "does not care" during what time of the day the water is heated and used. The CombiWATT function only supplies the preset minimum daily power to the boiler and thus making sure that there is enough warm water when the recommended configuration is used. In cases when even under the recommended configuration warm water is not available in required amount, we recommend to gradually increase the daily energy limit ("CombiWATT [kWh]") for example, in 1 kWh steps, in order to make sure that warm water is available and at the same time that not too much energy is consumed from public grid. This is recommended mostly for households where consumption of warm water is high at the evening. Here it may come to the situation where water is sufficiently heated during the present day by the PV-plant, but the next day the plant is not capable of providing the necessary amount of energy (cloudy weather). The CombiWATT mode may also be aided by enforcing the relevant output with a time schedule. Based on user preferences, time schedules may even completely replace the CombiWATT mode. For more information see chapter Setting up time schedules.

If you do not have low tariff signal available (either you don't have double tariff rate or the signal cannot be utilized) but you still want to use the CombiWATT mode, connect the GND terminal to the LT terminal. In such scenario, the low tariff signal will be active at all times and the CombiWATT mode will be activated after production of PV-plant comes to an end (after sunset).

## SETTING UP TIME SCHEDULES

For every output there may be set 2 independent time intervals. During these time intervals the relevant output may be forced to be switched on or the switching process may be prohibited (restricted). The enforcing/restricting process may be further conditioned with the presence of the low tariff signal and / or by the status of daily energy counters for the relevant output ("Supplied energy"-fields).

The actual configuration of time schedules is done on the "Time schedules" tab. For more setup information, see the chapter Description of WATTconfig ECO items, Time schedules tab.

## FB INPUT CONFIGURATION

The controller has 1 pulse input FB. It can be used to connect external energy meter or other device with pulse output which comply with FB input parameters listed in technical specification. The output signal of this device must always provide information about measured electric energy.

FB input is not required to be used and it plays an auxiliary role. FB input provides additional information to the controller which will be shown in the WATTconfig ECO software and optionally used for other purposes, such as statistics.

Values obtained from FB input only provide information for the user and are not used to control WATTrouter device outputs.

Configuration of the pulse input is done on the "Input settings" tab. For more information about the settings see the chapter Description of WATTconfig ECO items, Input settings tab.

## WIRELESS COMMUNICATION SETTINGS

**Note:** This function is accessible, once SC-Gateway module is inserted.

WATTrouter ECO optionally integrates wirelessly controlled stations (endpoint devices) which can be purchased as accessories. Wireless connection solution can be applied in buildings, where installation of wire connections between controller and devices would be too difficult.



**Before ordering this accessory function, assure that wireless devices will be accessible by the controller. The accessible distance is based on construction of the building and it is possible to extend this range by repeaters. Further information can be obtained from technical support.**

This function requires SC-Gateway module which needs to be inserted into the regulator. To install this SC-Gateway module, refer to the SC-Gateway user manual. It is also necessary to buy at least one wireless peripheral (wireless socket or another controller equipped with the SC-Router module).

As of firmware version 3.0, the wireless communication settings are part of the S-Connect protocol. For more detailed information on wireless communication settings, see chapter S-Connect protocol settings.

## S-CONNECT PROTOCOL SETTINGS

The device supports the S-Connect device sharing protocol since firmware version 3.0. For more detailed information on setting up this communication, see chapters Description of the S-Connect protocol and S-Connect tab.

## FINISHING THE CONFIGURATION

After setting up the device according to previous chapters, the controller is fully configured. You may save the preset configuration by pressing the Save button or you may load it at any time by pressing the Open button. This way you may create several different configurations and monitor them for some time and determine which one provides better utilization of energy self-consumption in your facility or household.

After you have completed the settings then in case of manipulating within the distribution box turn off entire distribution box, remove the USB cable and turn on the distribution box again.

**Tip:** In order to maintain continuous monitoring the controller can be kept connected via USB. If you want to use permanent USB connection, then it is recommended using a suitable USB isolator or USB connection extender via Ethernet.

## DESCRIPTION OF WATTCONFIG ECO ITEMS

This chapter contains a list of all items available in the WATTconfig ECO control software and explains their meaning.

### MAIN WINDOW

The main window displays all basic measured values and statuses. The controller can be configured using configuration tabs.

**Note:** Since firmware version 1.7 the layout of control elements and buttons has been reworked to be similar to WATTrouter Mx series.

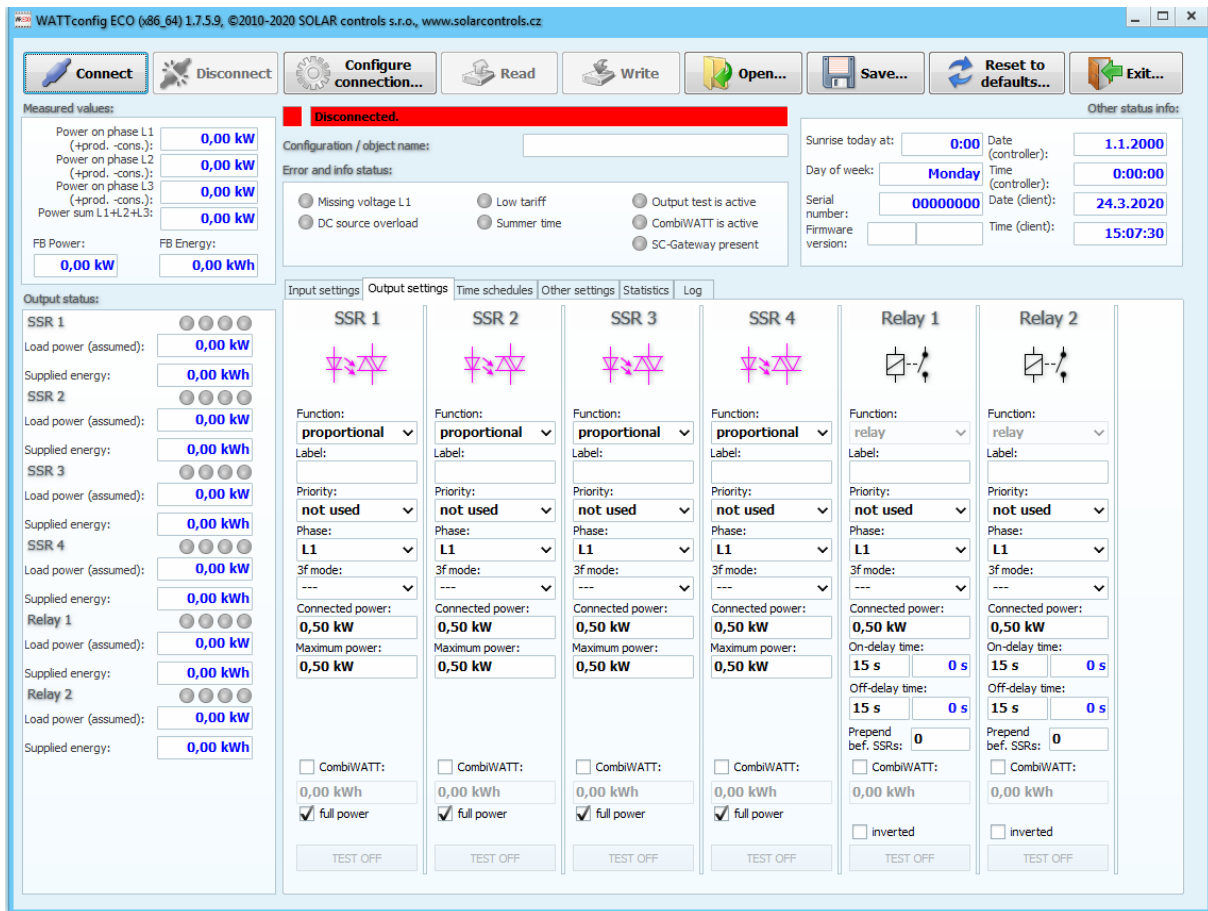

Figure 9: Main window of WATTconfig ECO software.

## MEASURED PARAMETERS AND STATUSES

### Measured values:

- Power on ph. L... - the actual value of the active power measured on the relevant phase wire. Positive value means production (PV-plant supplies power to the grid); negative value means that power is being drawn from the grid.
- Power sum L1+L2+L3 – sum of active power outputs in all three phases.
- FB power- presents electric power, which is registered by pulse input. The value is calculated by

$$\text{formula: } P[\text{kW}] = \frac{3600}{t_p[\text{s}] \cdot \text{Imp}_{\text{kWh}}}$$

Where:

P – resulting power value (this box)

$t_p$  – period of impulses

$\text{Imp}_{\text{kWh}}$  – pulse amount per kWh (see FB input configuration)

The measurement dynamics depends on the impulse frequency. It may be very small for small measured powers. The maximum measurable period of impulses is set to 15 seconds (at 1000 impulses per kWh it corresponds to output power value of 0.24 kW). If the measured power is lower, zero is displayed.

- FB energy – presents electrical energy, which is counted by pulse input. The value is calculated by

$$\text{formula: } E[\text{kWh}] = E_p[\text{kWh}] + \frac{\text{Imp}}{\text{Imp}_{\text{kWh}}}$$

Where:

E - resulting energy value (this box)

$E_p$  – initial energy input (see. FB input configuration)

Imp – pulse amount registered by FB input from the connection point. This counters are not listed anywhere.

$\text{Imp}_{\text{kWh}}$  – pulse amount per kWh (see FB input configuration)

Impulses are counted only if the regulator is operating. It is only an auxiliary and informative feature of the controller. Counted impulses are saved in the internal EEPROM memory every hour. In case of a short time power supply failure these values should not be very different from the actual reality. More frequent impulse saving is not possible due to technical reasons. If these values do not correspond with the value shown on the display of the connected energy meter, modify the field "Energy offset" to match the value of the energy meter, check the "Reset energy"-field and press the Write button.

### Error and info status (gray in inactive status, red in active status):

- Voltage L1 missing – no voltage was detected on phase L1 - this is a hardware error of the regulator and the regulator must be replaced or repaired. This fault blocks the power measurement and the active functions of the controller (output switching).
- DC source overload – (since firmware version 1.7) voltage of the internal DC source drops below + 9V relative to GND. This malfunction can occur when the internal DC voltage source is heavily loaded. The firmware since version 1.7 checks this and eventually signals this failure. This malfunction lasts for the

duration of the cause and for a further 60s afterwards. Typically, this failure occurs when all 6 internal outputs are used together with inserted SC-Gateway module. If this error occurs connect the control circuits of all used SSRs to an external source. This fault blocks the active functions of the controller (output switching).

- S-Connect: device error - (since firmware version 3.0) this error is reported if any device mapped in the S-Connect tab is not functional or the station that provides it is not connected. Which device is affected can be determined by the Ping [ms] value and the device activity indicator on the S-Connect tab. This fault does not block any functions of the controller, except for functions that depend on faulty shared devices.
- Low tariff – if the low tariff signal is detected the red light comes on, otherwise is grayed.
- Summer time - informs the user that the summer time mode is active. Summer time starts at 2:00 CET, on the last Sunday in March and ends at 3:00 CEST, on the last Sunday in October. If the option "Use summer time" is not marked on the "Other settings" tab, the indicator remains inactive.
- CombiWATT is active – informs the user that CombiWATT mode is active. This indicator is active if the condition necessary to run CombiWATT is valid, if the low tariff is active and if the CombiWATT function has been configured for some output.
- Output test is active – informs the user about a status when some of the outputs have been activated by the TEST button.
- SC-Gateway/SC-Router present – (since firmware version 1.7) informs the user about the presence of the SC-Gateway or SC-Router module in the controller.

In case of an error that blocks active functions of the controller, all outputs turn off and any control functions are stalled.

#### Output statuses:

- Load power - the assumed power drawn by the load connected to the relevant output. It refers to an estimated power based on the output settings and may not correspond with the actual power output of the load, as the power drawn by the connected load is not measured.
- Supplied energy - daily energy counters measuring power already supplied to the relevant output. It refers to an estimated energy supplied to the load, which is based on the output settings and may not correspond with the actual amount of the power supplied to the load, as the power drawn by the connected load is not measured. Energy counters inform CombiWATT mode or the corresponding time schedule about the energy already delivered to the load and at the same time, they also inform the user about the amount of delivered energy. Counters are reset to zero based on the configuration of "CombiWATT - Energy counter reset"-field in the Other settings tab. WATTrouter device does not know the status of the load and therefore, counters may also show much higher energy values than those actually delivered to the load (for example, if the boiler is heated up during the day and turned off by the thermostat).
- Status output indicators - inform the user about the reason for switching, or possibly about the reason for output restriction. There are 5 indicators:
  - a) Blue - it is displayed only if the output is switched on due to basic control process according to the available surplus energy from PV-plant. This indicator also signals possible off-delay time for the relay output (after being enforced by time schedule or CombiWATT mode).
  - b) Violet - it is displayed only if the output is switched on by the CombiWATT mode.
  - c) Green - it is displayed only if switching is enforced by time schedule.

- d) Red - it is displayed if the output is restricted by time schedule or consumption watchdog.
- e) Green - (since firmware version 3.0) is displayed when the output is forced to be switched on by a remote device via the S-Connect protocol, or when the output is forced to be switched on during duplication from another relay output.

**Other statuses:**

- Configuration/object name - it is used to set label to the facility or the current configuration. Text may contain maximum of 16 characters in ASCII encoding.
- Sunrise today – it displays time of sunrise for today. This time is calculated directly in the regulator based on the actual calendar date and the actual geographic location of the facility/building (see "Geographic location" on the "Other settings" tab). The calculated time is converted to the current local time based on configuration of the "Use summer time" and "Time zone" settings. The official sunrise zenith is considered, i.e. 90° 50'. Sunrise time is used to reset energy counters ("Supplied energy"-fields) in the main window, provided that the applicable mode in the field "CombiWATT – Energy counter reset" is selected, and also since firmware version 3.1 to start or end the time schedule.
- Sunset today – (since firmware version 3.1) it displays time of sunset for today. This time is calculated directly in the controller based on the current calendar date and the current location of the facility/building (see "Geographic location" on the "Other settings" tab). The calculated time is converted to the current local time based on configuration of the "Use summer time" and "Time zone" settings. The official sunset zenith is considered, i.e. 90°50'. The sunset time is used to start or end the time schedule.
- Day of week – (since firmware version 1.7) shows the current day of week, which is obtained from the controller date.
- Serial number- displays serial number and it is unique for each regulator.
- Firmware version – displays actual regulator firmware version.
- Date (regulator) – it indicates the real time running inside the regulator (date part).
- Time (regulator) – it indicates the real time running inside the regulator (time part).

**Note:** Regulator real time is backed up with a built-in lithium battery, so it runs even if the regulator power supply is turned off.

- Date (client) – it displays the real-time running on the PC (date part).
- Time (client) – it displays the real-time running on the PC (time part).

---

**INPUT SETTINGS TAB**

**In this tab you may set measuring inputs and the FB input.**

**Measuring input settings:**

- Current orientation - it is used to change the sign of measured powers, if the current sensing module is fitted in inverted position, or in cases for example, when it is desirable to pass the wire through the module in inverted direction.
- Phase - it is used to set the physical phase to given input when its function is set to power measurement. Assign the phase so that the measured currents are in phase with voltage. Check the assignment using a control oscilloscope and a purely resistive (thermal) load on the given phase.

**Note:** The Phase parameter replaces the "Phase Order Setting" menu from older WATTrouter models and allows you to set any phasing for all inputs with the power measurement function.

- Ratio for external CTs - set this ratio only if you use additional external current transformers (CTs), whose secondary coils are shorted with a wire passing through measuring coils of the current sensing module. If you use standard connection for WATTrouter device that is, the facility or household supply wire is passing directly through measuring coils, then this ratio should be 1:1 (however, this ratio can also be used to calibrate current measurement even in the case of standard wiring without external measuring transformers). External current transformers can extend the measuring range of the controller up to any value, depending on the conversion rate of the external current transformer.

**Example:** Let us say you want to use WATTrouter ECO in a facility where the main circuit breaker is rated up to 3x400A. In this case you have to buy external current transformers with ratio 400A:5A. Connect/short-cut their secondary terminals using a wire, and at the same time, pass it through measuring coils of the current sensing module (see figure 7). Now set the conversion rate to 400:5.

However, in order to use the full range of the built-in A/D converter, it is recommended to make 4 turns around the measuring coils to get optimum conversion rate of 400A:20A. Then, set the conversion rate to 400:20.

**Caution:** Use only external CTs for large facilities and large PV-plant power outputs. If you are using a high conversion ratio of external CTs, you have to take into account that (relatively) small power outputs (in the example describing the optimized conversion rate 400A:20A, the limit represents approximately 0.75 kW per phase) are below the resolution capacity of the measuring inputs and therefore, these power values will not be measured and equal to zero.

### FB Input configuration

- Energy starting offset - this field can be used to set initial values of measured energies. If the values of measured energies do not match the display on the connected energy meter (for example), put the value of the energy shown on the display into this column and reset impulse counters to zero by marking the option "Reset energy".
- Reset energy - used to reset energy counters to zero.
- Number of impulses per one kWh – this column is used to set the number of impulses per one kWh. Set the value according to the label or manual of the connected energy meter, inverter or according to another compatible measuring instrument. It is recommended to use highest possible amount of impulses per kWh to get better resolution for the FB power field.
- Measurement source – as of firmware version 3.0, this item is replaced by the more general items Input settings for statistics (see chapter Other settings tab), which better correspond to the advanced options when using the S-Connect protocol.

### Input checking oscilloscope:

This graph is primarily used to check the correctness of ILx metering inputs settings or the FB input settings. From the drop-down menu, select the input you want to check and follow the chart.

The oscilloscope will always display the events at the analog inputs of the WATTrouter microprocessor, which will vary according to the assigned input:

- a. ILx - one whole half-period of measured current is displayed, the value for zero measured power should be around 0-10 digits. For more information about this view, see chapter Setting up main function.



- b. FB - logic 1 (about 4000 digits) will be displayed for active pulse or logic 0 (about 10 digits) for the space between pulses from the meter.

## OUTPUT SETTINGS TAB

**On this tab you may set basic parameters for outputs and setup the CombiWATT mode for outputs.**

- Station – as of firmware version 3.0, this entry is no more available and is replaced by the device mapping on the S-Connect tab.
- Device index – as of firmware version 3.0, this entry is no more available and is replaced by the device mapping on the S-Connect tab.
- Function - used to set the functionality of the corresponding output:
  - a. Relay- the output will operate in On/Off mode (as a relay).
  - b. Proportional - (only for SSR outputs or when S-Connect protocol is activated, also for supported RO outputs) the output will operate in proportional control mode, by modulating connected load's power according to the available surplus energy.



**This mode is only for controlling the output of resistive (thermal) appliances and requires the connection of external power semiconductor relays (SSRs)! This mode can further increase the flicker (fast changes in mains voltage or fast flashing of light bulbs and fluorescent lamps). Before connecting the appliance to this mode, read the flicker recommendations in the Frequently Asked Questions section of the manufacturer's website.**

- c. PWM – (only for SSR outputs or when S-Connect protocol is activated, also for supported RO outputs, and also with activated SW package PWM mode for outputs) the output will operate in proportional control mode, by modulating connected load's power according to the available surplus energy, but the output will be PWM, see technical specification for PWM parameters.



**Caution: This mode is only suitable to control the output power of external devices (such as some battery chargers and heat pumps) which are equipped with this kind of control input. This mode cannot be used for external solid state relays!**

**Note:** If the Function field is disabled then either there is only one function possible (function that is shown) or (since firmware version 3.0) the function is set remotely by S-Connect protocol.

- Label – used to assign a label for the relevant output. Label may contain a maximum of 8 characters in ASCII encoding.
- Priority – it is used to set priority for the relevant output. First priority is the highest, sixth priority is the lowest (in case of activated S-Connect it is possible to configure up to 12 priorities). "Not used" means that the output is not activated. Output with higher priority will switch on "sooner" and will switch off "later" (see the chapter "Setting up main function"). If you are using the "Sum of all phases" control mode, you cannot select the same priority for two or more outputs (except for the "not used" status). In the "Each phase independently" control mode this settings must be applied to each phase. From the first (the highest) priority all the way down to the lowest priority. No gaps are allowed in the priority settings, that is, you cannot set only the 1st priority and the 3rd priority, without setting the 2nd priority as well. WATTconfig inspects priority and phase settings before writing them into the controller.
- Phase – if using the "Each phase independently" control mode you have to set the phase wire for each output where the relevant load is connected to. The setting must correspond with the reality. Use the TEST button to verify that.

**Note:** The output phases may not correspond to the physical phase settings for the ILx inputs. The reason is that for the inputs physical phase is assigned according to the actual connection of the current sensing module and for the outputs logical phase in relation to the inputs ILx.

- 3f mode – (since firmware version 1.7) when using the "Each phase independently" control mode you can set special method of surplus energy calculation to switch on or off this output. These special methods can be used only for symmetrical three-phase loads (such as 3-phase heating elements, 3-phase heat pumps and others), which have to be connected on 3-phase line. Connect those loads only via external 3-phase contactor or 3-phase power SSR or, if you have 3-phase inverter heat pump, use corresponding control module which can directly control the power of this heat pump.

The phase entry for the output in 3f mode indicates a *reference phase*, which is used only for assigning the output to the priority chain for that phase.

Put one third of nominal input power of the load to the Connected Power field and set phase and priority according to your preferences (the Phase field only serves here as reference parameter to include this output into correct priority chain). Following special methods of energy surplus calculation are available:

- a. Min (L1, L2, L3) – output will be switched on behalf on a minimum surplus energy from all 3 phases
- b. Avg (L1, L2, L3) – output will be switched on behalf on average surplus energy from all 3 phases
- c. Max (L1, L2, L3) – output will be switched on behalf on a maximum surplus energy from all 3 phases

Within the assignment of one phase there can be combined single-phase and three-phase loads at different outputs. Use this function with extreme caution and only if it is not actually possible to split given three-phase load to 3 single-phase loads (e.g. as the aforementioned 3-phase heating element).

- Connected power - it specifies the active power rating of connected load. If power rating is specified in VA and the power factor  $\cos(\Phi)$  is specified, you may determine the active power rating using  $P[W] = S[VA] \cdot \cos(\Phi)$  formula. The connected power value should be equal to the power rating of connected load for proportional or PWM function, and must be higher or equal for relay function.
- Maximum power – this value applies only for proportional outputs. It determines the maximum allowed power applicable for the connected load. In many cases this value is equal to the connected power value, but for example, due to limited SSR cooling possibility or due to saving the surplus energy for additional outputs, you may decrease this value. The value in the "Load power"-field may be slightly lower than the selected maximum power value, even if the output is fully excited and maximum power is reached. The reason is that outputs with proportional function do not switch on fully proportionally but only "quasi-proportionally", which means, only in certain switching levels.



**Always keep the value equal to the Connected power value in cases where the output is set to the proportional function, causing an increased flicker (fast changes in mains voltage or rapid flashing of light bulbs and fluorescent lamps). The output will always be permanently switched on when fully excited. See the flicker recommendation in the Frequently Asked Questions section of the manufacturer's website.**

- Prepend before SSRs – allows prepending the relay output before specified number of proportional outputs. Fill in 1 if you want a relay with lower priority to switch on when assumed load power on nearest higher priority proportional output reaches the relay's "Connected power" value. Fill in 2 if

you want this relay to be switched on when sum of load powers on nearest 2 higher priority proportional outputs reaches the relay's "Connected power" value. The function works similar for higher values. This function will violate the preset order of priorities. However, it allows using almost all available surplus energy even if heating elements are connected to relay outputs. For example, if you are using a three-phase heating element.

**Example 1:** heating element 3x2 kW connected and configured in the following way:

- 1st heating coil connected to SSR No. 1, 1st priority, connected power 2 kW, maximum power 2 kW
- 2nd heating coil connected to relay No. 1, 2nd priority, connected power 2 kW, prepend value = 1
- 3rd heating coil connected to relay No.2, 3rd priority, connected power 2 kW, prepend value = 1

If the SSR No. 1 is fully switched and consumes 2 kW of surplus energy and the amount of surplus energy further increases, then the relay No. 1 will switch on and SSR No. 1 will automatically reduce its power. If the surplus energy increases by additional 2 kW so that the SSR No. 1 is fully switched again, the relay No. 2 will be switched and SSR No. 1 will again automatically reduce the power output. If the power output continues increasing, additional outputs with lower priorities will be connected. Similarly, outputs will disconnect when the PV-plant power generation will decrease.

**Note:** To make sure that the function works correctly, all 3 heating coils must be active (heated) at the same time or inactive (disconnected by the thermostat). The algorithm will not work correctly if heating coil No. 1 is disconnected by the thermostat and the other two heating coils will continue producing heat. In this scenario, the relay will be continuously connected and disconnected because the controller is trying to keep "virtual zero" or "phase zero", depending on control mode, and is not able to determine from phase wire measurements that heating coil No. 1 is disconnected.

**Note:** In order to ensure correct function of the algorithm it is necessary that the SSR - to which heating coil No. 1 is connected, is assigned with the higher priority than the relay No.1 with the 2nd heating coil. If heating coil No. 1 connected to SSR has lower power rating than the other two remaining heating coils, relays will connect only after the overall power (power drawn by the first heating coil + surplus energy) exceeds the value of "Connected power" field set for relay No. 1. In this case, the part of surplus energy will be still delivered to public grid as in the case of the default function of WATTrouter controller.

**Example 2:** A boiler and 2 other heating elements:

- Boiler connected to SSR No. 1, 1st priority, connected power 2 kW, maximum power 2 kW,
- 1st heating coil connected to SSR No. 2, 2nd priority, connected power 2 kW, maximum power 2 kW,
- 2nd heating coil connected to relay No. 1, 3rd priority, connected power 2 kW,
  - a) Prepend value set to **0**: In this case the 2nd heating coil will never be prepended and after 4kW surplus is reached and consumed by boiler and 1<sup>st</sup> heating coil the controller will wait until the total available surplus is 6kW. Then it connects 2<sup>nd</sup> heating coil. In the meantime surplus flows to public grid.
  - b) Prepend value set to **1**: In order to prioritize the 2nd heating coil, we will take into account only the assumed load power of the 1st heating coil, which means that the boiler will always have first priority. So after total surplus reaches 4 kW the 2nd heating coil will be connected (prepended) before the 1st heating coil.
  - c) Prepend value set to **2 and higher**: In order to prioritize the 2nd heating coil, we will take into account the sum of assumed load powers of the boiler and 1st heating coil. So after total surplus reaches 2 kW the 2<sup>nd</sup> heating coil will be connected (prepended) before boiler and 1<sup>st</sup> heating coil.

**Note:** The Prepend function does not affect relay output priorities. For example, if the relay 2 is set to the nearest lower priority than the relay 1 but has a higher Prepend value than the relay 1, the relay 2 will not be prepended before the relay 1. Therefore, in this case, higher Prepend value for relay 2 than for relay 1 is not meaningful, so don't set it.

- Minimum power – for proportional outputs when PWM function is used then this value gives the minimum power for the connected load. The output will not be activated unless available surplus energy exceeds this threshold. Nonzero value can be useful e.g. for proportional control of inverter air conditioner or heat pump. These devices usually don't run with less than 1/3 of nominal power. For more information about controlling air conditioners or heat pumps proportionally see manufacturer's web site.
- @ – (since firmware version 3.1) for proportional outputs when PWM function is used, it allows you to enter the output excitation level corresponding to the item Minimum power. The excitation level is entered as a percentage of the full cycle of the PWM signal or full voltage range 0-10V. Up to and including firmware version 3.0, the level was fixed at 10%/1V.

**Example:** Let's have a heat pump, controlled by the external 0-10V signal, connected to the SSR output with the PWM function set. The smallest pump power is 1kW, which corresponds to a voltage of 3V. The highest pump power is 3kW, which corresponds to a voltage of 10V. The pump switches off at a voltage of <0.5V. Then we set Connected power=3kW, Minimum power=1kW and item @=30%. PWM-range remains full 0-100%. The controller will then switch this pump in the range of 1kW to 3kW, which corresponds to 3V to 10V. If it needs to be turned off, the controller will set it to 0V.

- PWM-I – for proportional outputs when PWM function is used then this value is equal to the I-component value of the PID-regulator assigned to this output. The value can be selected between 1 and 1000. Select value according to the dynamics of the connected system (battery charger, heat pump etc.). Start with a small value (1 to 10) and gradually increase the value if the system dynamics is slow. For values less than 100 the dynamics is rather slow so that the system will enable to switch outputs with lower priorities, to cover available surplus energy. If the Minimum power field is nonzero the control will start after 3 minutes. In the meantime minimum power is held – aimed for soft-starts of air conditioners or heat pumps.



**Caution: In case of a too big PWM-I value the system may become unstable and this status may damage the connected device, when there is no built-in protection in the device!**

- PWM range – (since firmware version 1.7) these values can be used to limit physical PWM or 0-10V output to given subrange. Here we suppose a PWM/0-10V converter is used that converts PWM signal of the output to 0-10V signal. For example, if we need a signal that is 1-10V (1V corresponds to zero power, 10V corresponds to full power) then we set 10-100%. Similarly if we need a signal that is 2-5V (2V corresponds to zero power, 5V corresponds to full power) then we set 20-50%. The output within this range is linear and even for the smallest possible subrange (10% of the full range, so e.g. 10-20% i.e. 1-2V) is fine enough and has minimum resolution of 100 levels (for smallest subrange of 1V it means the resolution is 10mV).
- On-delay time – this value applies only for relay outputs. This delay time runs from the moment a condition has been detected to switch the relay output on. By this condition we mean that the corresponding energy surplus exceeds the limit set by the "Connected power" field, which is further increased by internal fixed hysteresis of 0.1 kW. After the time elapses the relay is really switched on. It is recommended to use the default value, or to slightly increase it if the relevant load cannot be switched on frequently. The value may be decreased down to 2s. However, such small delay time may

sometimes cause false load switching. Therefore, we recommend decreasing the value only in certain cases and after proper testing. This time delay is not active in CombiWATT and TEST mode.

- Off-delay time - this value applies only for relay or PWM outputs. For relay outputs this delay time runs from the moment a condition has been detected to switch the relay output off. After the time elapses the relay is really switched off. This feature is necessary for loads which cannot be switched on frequently. The value may be reduced down to 2s. For example, for heat pumps we recommend increasing this value significantly. This time delay is not active in CombiWATT and TEST mode. Here it is assumed that the low tariff activity time is always sufficiently long in case of double tariff rates.

For proportional outputs when PWM function and nonzero minimum power is used this value gives the switch off delay for case air conditioner or heat pump is connected to this output and controlled by PWM mode. If there is not enough surplus energy to run the device anymore the device will continue to run at minimum power for specified amount of time. The delay in this case cannot be set to less than 3 minutes.

- Duplicate to - (since firmware version 3.0) allows you to duplicate the relay output switching to another relay output that is selected in this field.

**Example:** Consider a three-phase pool heater operated in the control mode of each phase separately. Here we need to ensure the operation of the pool water circulation pump when switching on the pool heating in any phase. We will use 3 relay outputs in the first priority on each phase, where the circulation pump is connected to the relay output on phase L1. We will also use 3 SSR outputs in the second priority on each phase, which proportionally switch the individual heating coils of the pool heating. Duplication ensures switching of the relay output on L1 even in case there is no PV surplus on L1, but it is on L2 or L3.

**Note:** When you select an output that has no relay function set, duplication does not apply.

- CombiWATT – activates the CombiWATT mode for the relevant output (output must be activated, i.e. to have assigned valid priority). Enter the required amount of energy power, which must be supplied to the corresponding load every day.
- Watch consumption – (since firmware version 3.1) mark this field if you want to restrict this output by the consumption watchdog, upon meeting the other conditions for its restriction.
- Full power – mark this field if you want to switch the proportional output in CombiWATT or TEST mode at full power, regardless of the Maximum power setting ("Maximum power"-field). In this way you may eliminate the occurrence of disturbing flicker effect (produced by light bulbs or fluorescent lamps) when CombiWATT or TEST is active. If you don't check this field the specified maximum power for the load is used in CombiWATT or TEST mode.
- Inverted – this checkbox applies only for relay or PWM outputs. When checked, the selected output will be switched on in inactive status and switched off in active status. Since firmware version 1.7 this inversion is active in all cases (independent from priority assignment or even the TEST status). There is only one exception when a failure is detected. In this case the inverted relay output will remain physically turned off.

This function in case of a relay output can be useful when you want to avoid delivering surplus energy to public grid. Here, typically, one relay output is set as inverted and assigned to last priority. And it is used to block the inverter. If there is inconsumable surplus energy (typically in hot summer) this relay output disconnects the inverter for some time (given by Off-Delay time). After this time the inverter starts again. To block the inverter it is recommended to use analog inputs of the inverter (for inverters

which support power reduction). In this configuration the inverter will be disconnected from grid on each WATTrouter failure or when WATTrouter itself gets disconnected from grid.

In case of the output with PWM function, the output duty cycle of the PWM signal is inverted.

**Attention:** *As of firmware version 3.0, the output can also be switched on by an external station when the S-Connect protocol is activated. In this case, the inversion does not apply! If you want the output to be inverse and you also want to switch it externally, you must also set the inversion of the corresponding remote output on the external station (however, not all stations support this).*

- TEST – it is used to test the relevant output and load. If you press the TEST button then the corresponding output is forced to switch on, independent from its current configuration. If the output is inverted then since firmware version 1.7 the test mode is also inverted, i.e. it switches off. The behavior of all other control functions depends on the “Output test blocks control” option state as described in chapter Other settings tab.

## TIME SCHEDULES TAB

**On this tab you may set time schedules for individual outputs.**

Up to 2 independent time intervals may be set for each individual output. During these time intervals the relevant output may be forced to be switched on, or the switching process may be restricted. Enforcing or restricting may be further conditioned by the binary input status and / or by the status of daily energy counter for the relevant output (fields "Supplied energy").

You may use time schedules to create more complex configurations for outputs, based on user preferences. You may also use time schedules to add or possibly replace the built-in CombiWATT mode.



**Time schedules operate independently of the basic regulation mode. If used inappropriately, time schedules may worsen the energy efficiency of your facility. Setting up time schedules depends entirely on your creativity and provides a wide range of different combinations. Only advanced users should use time schedules and only after they have been thoroughly familiarized with the applicable functionalities of this device!**

**Description of a time schedule option:**

- Time schedule mode:
  - a) Not used – time schedule is not active.
  - b) Restricted – the output will be restricted during the interval specified in the "From - To" field. If the "From" time is larger than the "To" time, the restrictions or limitations are valid from the "From" time to midnight and on the next following day from midnight to the "To" time.  
**Restriction applies to all activities of this output and has the highest priority.** During the time interval neither basic regulation - based on the surplus energy - nor the CombiWATT mode will work. Neither any other time schedule set to enforced mode will work. Output restriction does not prevent outputs with lower priorities from working regularly.
  - c) Enforced - the output will be enforced/switched-on during the time specified in the "From – To" interval. If the "From" time is larger than the "To" time, the enforcement is valid from the "From" time to midnight and on the next following day from midnight to the "To" time. **Enforcement has the second highest priority** and it may be disabled only with another time schedule set to the restricted mode at the same time. During the preset time interval the output enforcement deactivates the basic regulation mode based on surplus energy (only if the Power field is set to 100%). However, it does not affect conditions for the activation of CombiWATT mode, which then

can run simultaneously with the enforcement mode. Output enforcement does not prevent outputs with lower priorities from working regularly.

- Activity indicator – (since firmware version 3.2) shows the activity of the time schedule. These indicators are useful if you use multiple schedules for a single output.
- From – time when time schedule begins. Since firmware version 3.1, the following times can be set:
  - a) Time – the entered time is used
  - b) SR – sunrise time is used + given offset
  - c) SS – sunset time is used + given offset
- To – time when time schedule ends. Since firmware version 3.1, the following times can be set:
  - a) Time – the entered time is used
  - b) SR – sunrise time is used + given offset
  - c) SS – sunset time is used + given offset
- Power – (since firmware version 1.7) it can be configured for proportional outputs (if the function is proportional or PWM). This field can be used here to enforce or restrict the output power as a percentage of the connected power. Thus, the output can be switched proportionally even when switched by the time schedule.

Since firmware version 3.1, the Power item behaves differently depending on the time schedule mode and the Minimum power value for the PWM function. Conversion tables of the Power item to resulting PWM signal, or voltage 0-10V, follow. These conversion tables apply in the case of full PWM range (PWM Range item) and no output inversion:

- a) Enforced mode:

Power [%]	Smallest PWM duty cycle [%]	Lowest voltage [V]
0	Cannot configure	Cannot configure
1	1	0,1
10	10	1
20	20	2
...		
90	90	9
<b>100 (fully enforced)</b>	100	10

**Important:** If the PWM output function is selected, a non-zero Minimum power is set, and the Power item is lower than what would correspond to the percentage excitation in the @ field, the output will not be forced. This serves as protection against powering the connected appliance outside the specified operating range.

**Note:** If in the Enforced mode the output power is set to be lower than 100%, then such enforcement does not deactivate the basic regulation mode according to excess energy. So if the output is forced to e.g. 50% and there is a surplus energy available to switch it to 75%, the output will switch to 75% power.

- b) Restricted mode:

Power [%]	Biggest PWM duty cycle [%]	Highest voltage [V]
<b>0 (fully restricted)</b>	0	0
1	1	0,1
10	10	1
20	20	2
...		
90	90	9
<b>100</b>	Cannot configure	Cannot configure

**Important:** If the PWM output function is selected, a non-zero Minimum power is set, and the Power item is lower than what would correspond to the percentage excitation in the @ field, the

output will be fully restricted. This serves as protection against powering the connected appliance outside the specified operating range.

**Note:** If in the Restricted mode the output power is set to be higher than 0%, then such restriction does neither deactivate the basic regulation mode according to excess energy nor the enforced time schedule. So if the output is restricted to e.g. 50% and there is a surplus energy available to switch it to 25%, the output will switch to 25% power.



**In the Enforced mode, always keep the Power value equal to 100% in cases where the output is set to the proportional function, causing an increased flicker (fast changes in mains voltage or rapid flashing of light bulbs and fluorescent lamps). The output will always be permanently switched on when fully excited. A similar recommendation also applies to the Restricted mode, where the Power value should always be equal to 0%. See the flicker recommendation in the Frequently Asked Questions section of the manufacturer's website.**

- M to S – (since firmware version 1.7) shortcuts for weekdays. The time schedule will be active only on checked days.
- LT – this checkbox is not available since firmware version 3.1. It has been replaced by the more general Binary Input condition.
- Binary input – (since firmware version 3.1) if you mark this field, the time schedule activity additionally depends on the state of the binary input. The function is different depending on the time schedule mode:
  - a) Restricted mode – the output will be restricted only if a binary input is selected and it is switched off when the ON condition is set or switched on when the OFF condition is set.
  - b) Enforced mode – the output will be enforced only if a binary input is selected and it is switched on when the ON condition is set or switched off when the OFF condition is set.
- Energy – if you mark this field, the time schedule activity additionally depends on the status of the daily energy counter of the relevant output (the "Supplied energy" fields). Again the function differs based on the time schedule mode:
  - c) Restricted mode – the output will be restricted only if the daily energy counter exceeds the value specified in the Limit field.
  - d) Enforced mode – the output will be enforced only if the daily energy counter did not yet reach the value specified in the Limit field.

**Tip:** Time schedules may also be set for an output which does not have any assigned priority. These outputs may be used for example, as time switch clock etc. Labels and "Connected power" field may be configured for these outputs using the Output settings tab. "Connected power" field of such output is then used to update the daily energy counter.

**Note:** The conditions described above combine with logic AND within one time schedule. If you need to create a logic OR combination, you need to add a second time schedule with the same time range and another condition. For example, if the schedule should restrict the output function in case where the energy counter exceeds the 5 kWh limit AND the low tariff is present, just use one time schedule where both conditions are set. If this should limit the output function in case where the energy counter exceeds the 5 kWh limit OR the low tariff is present, it will be necessary to use 2 time schedules with the same time limits but each set for a different additional condition.

**Note:** Impact-free transition to the basic regulation mode: If the condition necessary for the enforcement of a relay output no longer exists, a basic 10s delay is set for this output. This delay is used to ensure impact-free transition to the basic regulation mode. Similar method is also used for proportional outputs.

For more practical samples demonstrating configuration of time schedules, see the chapter Configuration examples.



## OTHER SETTINGS TAB

**On this tab you may configure general control settings and other advanced device settings.**

### Control settings:

- Control mode - it is used to set the basic control mode:
  - a. Each phase independently - the controller will control outputs according to measured active power on each phase wire separately. In this mode it is necessary to correctly set phases for all active outputs. They must correspond with the phase wire where the load is connected to.
  - b. Sum of all phases - the controller will control all outputs according to the sum of measured active powers from all three phases. In this mode it is not necessary to set phases for individual outputs as this does not matter.
- Power offset – this field specifies the difference between the actual sum of measured powers in 3 phases L1+L2+L3 and the value used for the control purposes. For example, if the actual sum of measured powers L1+L2+L3 equals to +500W and the power offset equals to -100W, the controller will use the value of 400W to determine the conditions for output switching. Above terms apply for the "sum of all phases" control mode. For the "each phase independently" control mode this power offset value applies for each phase independently. The lower (more negative) the power offset is, the more power consumption from grid is avoided in transitional statuses as well as in stable statuses where the proportional outputs pass only small amount of power to the load. Transitional statuses are usually identified by 4-quadrant energy meters as "movement around zero", where production and consumption indicators change irregularly and fast. Negative power offset avoid showing up the consumption indicator, but during normal and stable control statuses some surplus energy flows unused into public grid. If you use standard connection and configuration, then it is not recommended to use positive offset.
- PWM frequency – (since firmware version 1.7) set the desired frequency for outputs with PWM function. This frequency is always the same for all outputs (and cannot be set differently by hardware).
- Internal DC source - (since firmware version 1.7) informs about the voltage value of the internal DC source of the controller. This value is used to check for eventual overloading of the internal power supply, which may lead to the "DC source overload" fault. See chapter Measured parameters and statuses for details.
- Output test blocks control - (since firmware version 1.7) this function is used to set the output behavior in TEST mode. If this option is checked, the test mode behaves as in all older firmware versions and thus activating any output to the TEST mode completely stops the control. If this option is unchecked, the TEST mode does not block the control of other outputs that are not in the TEST mode.
- Output test timeout - (since firmware version 1.7) this item is used to limit the duration of the TEST mode activity. If the entry is zero, the TEST mode is unlimited and behaves as in all older firmware versions. If the item is non-zero, the TEST mode will be limited to the specified time. The value is the same for all outputs. This new function can be used, for example, to temporarily switch an output in manual mode, if it is necessary to quickly force a certain output to switch on for a limited period of time.

### Date and time settings:

- Synchronize date and time with the client - check this field if you want to synchronize the controller date and time with the actual time running in your PC.

- Use summer time - check this field if you want the controller to perform automatic switching between summer and winter time. Based on EU recommendations only summertime is supported, which starts at 2:00 CET on the last Sunday in March and ends at 3:00 CEST on the last Sunday in October. The summertime information is used to automatically modify the current time as well as the calculated sunrise time.
- Time zone - specify the time zone based on your country. The default value uses Central European time. This value is only used to modify the calculated sunrise time. Time zones outside of multiples of full hours are not supported.

**CombiWATT settings:**

- CombiWATT delay time – specifies the time delay from the moment where PV-plant production is not detected anymore (after sunset) until CombiWATT can become active. It is recommended to increase the setting if you are frequently using electrical loads (other loads than those connected to the controller), which consume entire surplus energy of the PV-plant for long time. In this case, the controller cannot recognize that PV-plant production is not yet over.
- Time to activate CombiWATT – it displays the remaining time before activation of the CombiWATT mode. The value is equal to the "CombiWATT delay time"-parameter, provided that some surplus energy is still detected. If the value equals to zero and low tariff signal is detected at the same time, the system activates the CombiWATT mode for corresponding outputs.

- CombiWATT production limit – small amount of active production or surplus energy (single units or tens of Watts) may be detected for facilities with significant capacity loads (blocking capacitors, UPS stations, large number of switching sources, etc.), even though the inverter does not work. The cause may be even the inverter itself. In this case, the regulator displays small amounts of positive active power in either phase wire. Reason for this is significant reactive power, which is drawn by those devices and measured by WATTrouter near the "recognition line" between production and consumption. Also watt meters produced by different manufacturers behave in similar way. This item partially tries to resolve this issue by setting additional offset valid for each phase wire.

For example, if the production limit equals to 0.05 kW, CombiWATT mode will already be initiated (provided that also other requirements for the initiation of this mode are met), even if the production falls below 0.05 kW in each phase.

- CombiWATT – Energy counter reset – this field is used to reset energy counters, which represent the reset of the "Supplied energy"-fields in the main window. You have two options:
  - a) At sunrise: counters are reset if the time equals the sunrise time valid for this day.
  - b) At fixed time: counters are reset if the time is the same as the time set in the field called "Fixed time for energy reset".
- Fixed time of energy reset – it specifies a fixed time for energy counter reset mode according to fixed time (the previous paragraph, mode b).

**Geographic location:**

- Latitude - enter the latitude (in degrees) here. The value is used to calculate the sunrise time and therefore, values specified in degrees are precise enough.
- Longitude - enter the longitude (in degrees) here. The value is used to calculate the sunrise time and therefore, values specified in degrees are precise enough.

**Tip:** By changing the longitude you may modify the sunrise time in order to reset energy counters according to your preferences, for example, based on how large area is covered by shadow, etc. If you are not sure, do not modify these values. The default geographic location is set to Central Europe (CZ).

#### Other settings:

- Consumption watchdog - (since firmware version 3.1) enter the value of the main circuit breaker in amperes if you need to ensure that the consumption on some phase does not exceed the limit of the main circuit breaker and it does not disconnect. If you have a three-phase circuit breaker (eg 3x25A), set the limit in one phase (ie 25A). When the consumption limit is exceeded, the controller disconnects the currently switched outputs.

**Note:** If the value of the main circuit breaker exceeds the measured range (e.g. a 25A circuit breaker used in a standard variant with a measuring range of 20A), you must set a limit for the consumption watchdog at most equal to the measuring range (e.g. 20A). Although the controller will measure larger currents inaccurately, it will measure higher values and the consumption watchdog will therefore work.

The consumption watchdog only works in the following cases:

- a) The configured limit in A is non-zero (positive).
- b) The control mode of each phase independently is set, so that the controller knows to which phase the given output is connected.

If a greater consumption is detected for a given phase than corresponds to the set limit in A, the controller gradually disconnects all currently connected outputs, if their disconnection makes sense.

The following conditions apply to output disconnection:

- a) The output is switched on.
- b) The checkbox “watch consumption” is marked for this output.
- c) The current power of the connected load (assumed or measured) is sufficient so that after disconnecting the output, the consumption on the given phase is less than the specified limit in A.
- d) If the current power of the connected load (assumed or measured) is not sufficient so that after disconnecting the output, the consumption on the given phase is less than the specified limit in A, then the given output is disconnected only when the options for disconnecting outputs ad c) have been exhausted.

The output is completely disconnected in 3s from the evaluation of all these conditions.

The following conditions apply to the reactivation of the output:

- a) The output is disconnected by the consumption watchdog.
- b) The current consumption per phase is low enough so that when the output is reconnected to any power level of the connected load, the consumption per phase is less than the specified limit in A.

The output will be reconnected in 60s from the evaluation of all these conditions.

If the output is disconnected by the consumption watchdog, this is indicated by a red indicator, as well as in the case of time schedule restrictions.

**Note:** If the output is set to three-phase mode (min., avg. or max.), then it means that a symmetrical three-phase consumer is connected. The latter can increase consumption both on its reference phase (that is, the phase that is set for it) and on other phases. As part of the calculations of the conditions

for disconnecting this output, the maximum consumption on all phases is taken, not just the consumption on the reference phase.

**Note:** The regulator selects the appropriate output to disconnect exclusively according to the currently measured or expected power of the connected appliance. The priorities assigned to the outputs for the purpose of regulation according to PV surpluses do not play a role.

- Default tab - Set the tab in the WATTconfig you wish to appear when you launch the program. This setting is stored by WATTconfig software on PC hard drive.
- Default statistics tab - (since firmware version 1.7) set the subtab on Statistics tab you wish to appear when you launch the WATTconfig program or web interface. This setting is stored by WATTconfig software on PC hard drive.
- Sort outputs by phase and priority - (since firmware version 3.2) check this field to sort outputs by phase and priority. This ordering may simplify the configuration of the device outputs in some situations. E.g. when activating the S-CONNECT protocol, when only logical RO outputs are used. The outputs will be sorted in the Output settings and Time schedules tabs, as well as in the Output status table.
- Reset unit on configuration write - check this field if you want to restart the controller after each configuration was written.
- WATTconfig language - select the language which you want the WATTconfig ECO software to use after restart. The Custom item may be used for any other, still not supported language. If you want to use this option, you have to manually translate strings in the *custom.xml* file into the language you want to use.

#### Table of wireless stations:

As of firmware version 3.0, the wireless communication settings are part of the S-Connect protocol. For more detailed information on wireless communication settings, see the chapter S-Connect tab.

**Note:** When upgrading the firmware from an older version, the controller will try to convert the original settings of the wireless station table to the S-Connect station table, including the original settings of the remote WLS outputs.

#### Input settings for statistics:

As of firmware version 3.0, the source inputs for calculating data on the Statistics tab can be set more precisely. In older firmware versions, it was only possible to select FB input for measuring or capturing photovoltaic production, in the Measurement source field corresponding to the FB input. In newer versions, it is already possible to select inputs both for determining the production of photovoltaics and for determining (measuring) consumption and surpluses, for all 3 phases.

For any phase and any category (consumption, surplus, production of PV) it is now possible to select any input that measures or captures information about the instantaneous active power.

- Consumption - the power measured by the assigned input is registered in the Cons. NT or Cons. LT fields of the relevant phase, according to the validity of the low tariff. If the assigned input is the same as the input in the Surplus column for the given phase, then only negative values are registered.
- Surplus - the power measured by the assigned input is registered in the Surplus field of the respective phase. If the assigned input is the same as the input in the Consumption column for the given phase, then only positive values are registered.
- Production - the power measured by the assigned input is registered in the Production field of the relevant phase.

If the same input is assigned to several phases in a given category, then the measured power is divided evenly by the number of these phases.

**Example:** If the FB input is assigned to the Production field on all phases, then this means that the power of the three-phase PV-inverter is determined by this input, and this power is evenly divided into three phases.

By default, the IL1-3 inputs are set to detect consumption and surpluses, as was the case in older firmware versions, and the production inputs are unoccupied.

**Note:** When upgrading the firmware from an older version, the controller will try to convert the original FB input settings (Measurement source settings) to the Production items.

#### Buttons:

- Update firmware button - allows you to update firmware of this product. Updates are freely accessible in Download section at manufacturer's web pages. If there is an update available you may download it and install it. The progress of the update process is indicated on screen and it takes about up to 60 seconds.



**Update of original firmware is completely safe. The system fully and thoroughly inspects the integrity of the update file, as well as the integrity of data after downloading. In case of a power failure during the update, you may download the firmware again at any time after your power is restored. Should you experience an unsuccessful firmware update repeatedly, you may file a claim pursuant to valid trade terms and conditions. It is strictly prohibited to modify the downloaded file in any way. If you modify the downloaded file and even if the system inspected the integrity, you may still damage your product and lose your warranty!**

- Buy additional features- display dialog with the same name, where you can purchase optional SW features and activate them in the controller. For more details, see chapter Buy additional features window.

## S-CONNECT TAB

**As of firmware version 3.0, the S-Connect protocol can be configured on this tab.**

For more information on the S-Connect protocol itself, see chapter S-Connect protocol settings.

- Communication mode - selects the protocol mode for this unit:
  - a) Turned off - the protocol is not used. If the protocol is switched off from the previous active state, its entire configuration (station table and device mapping) is deleted and the data exchange with the unit is terminated.
  - b) Access Point (AP) - the unit acts as an access point that controls the operation of remote stations and their pairing.
  - c) Station (STA) - the unit acts as a station that responds to access point messages.

**Note:** If the S-Connect protocol is activated (ie AP or STA modes), then the configuration options of logic devices are displayed in the control interface of the device.

**Note:** If the SC-Gateway module is inserted in the device, the communication mode is automatically set to access point (AP). If the SC-Router module is inserted in the device, the communication mode is automatically set to the station (STA). Therefore, when inserting these modules, the S-Connect protocol cannot be switched off or set to another mode.

**Note:** Activating the S-Connect protocol does not block other functions of the device, as was the case when the SC-Router module was inserted in older firmware versions. It is thus solely the user's choice which function of the device to use. If the device is only used as a station for expanding the number of outputs, it is recommended

*not to activate local control functions, which themselves affect the switching of outputs, unless the user has a good reason to do so.*

- Autodetect new stations – (since firmware version 3.2) this option affects the station pairing on the Ethernet line:
  - a) Automatic detection (default behavior, option is checked) – new stations will be paired automatically according to the UDP or ARP broadcast messages.
  - b) Manual detection (option is not checked) – new stations must be paired manually by pressing the Manually detect station button.
- Delete ignored stations – when checked, this will clear all stations that were previously rejected by the user, ie the request to pair them was rejected (Ignore button). This option will allow you to re-pair previously rejected stations. The option is only enabled if some previously rejected stations are stored in the controller. For this option to be effective, the configuration must be written to the controller.
- Detect station manually – (since firmware version 3.2) – in manual pairing mode, press this button and then enter the IP where a new station is available. The controller will try to find the station. The detection may take longer time depending on the type of station (usually 2-60s).

**Note:** *Due to the lack of an Ethernet interface, the Watrouter ECO controller does not support manual pairing of stations, so the corresponding commands are not allowed.*

#### Remote station table:

This table shows the essential data of the paired stations. The number of table rows varies depending on the communication mode. In the case of an access point, the table has 6 rows, so a maximum of 6 remote stations can be added. In the case of a station, the table has only 1 row, which is reserved for access point information.

- Type – indicates the type of station, which can be:
  - a) Not used – the table row is not used
  - b) Ethernet – (AP only) the station communicates via a computer network (Ethernet or WIFI)
  - c) Tasmota HTTP – (AP only, since firmware version 3.2) the station equipped with the Tasmota firmware communicates via a computer network (Ethernet or WIFI)
  - d) Shelly HTTP – (AP only, since firmware version 3.2) the station equipped with the Shelly firmware communicates via a computer network (Ethernet or WIFI)
  - e) Wireless – (AP only) the station communicates wirelessly via the embedded SC-Gateway
  - f) Access point – (STA only) this is the access point
- MAC address – the MAC address of the station is displayed in this field. For stations communicating via Ethernet this is the Ethernet MAC address (last 6 bytes, the first 2 bytes are zero), for stations communicating via the SC-Gateway wireless interface this is the wireless MAC address (8 bytes).
- Name – in this field you can name the station. If the name is not filled in by the user, it is pre-filled in from the station identification data if these are transmitted via the S-Connect protocol (for stations communicating via Ethernet, the station name is transmitted, for wireless sockets it is not transmitted).
- Configuration name – this field displays the name of the station's configuration, if this information is supported by the station and has been filled in.
- Serial Number – this field displays the station's serial number, if supported by the station.
- IP Address – (Ethernet only) this field displays the IP address that is currently assigned to the station.
- LQI – this field displays information about the signal quality of the station's connection. For stations communicating via Ethernet, 100% is always displayed because this physical layer does not communicate the relevant data. For stations communicating via WIFI, the RSSI parameter converted to percentage value is displayed. For stations communicating via the SC-Gateway wireless interface,

the signal quality between the station and the nearest access point is displayed (this is either the SC-Gateway or the nearest signal repeater).

- Message counter – this field shows the number of messages that have been sent to the respective station. If the number of messages exceeds  $2^{32}$ , the messages are counted again from zero.
- Ping – this field displays the station response in milliseconds. The term response refers to the actual response of the station from the moment a message is sent to the station to the receipt of the response, increased by a pause in the communication which is inserted by the access point. Communication pauses are necessary to maintain communication stability and to optimize the use (non-overloading) of the controller's network interface.

**Note:** The access point operates all stations of the same type cyclically. The response thus increases in proportion to the increasing number of stations of the same type in the station table. For example, if all 6 stations are occupied and all are of the same type (eg Ethernet), then the response will usually be 6 times longer than the response of one station (if we consider a similar response for all stations). If a station is unavailable, then the station response increases by a preset response timeout.

- Station status indicator – is displayed in green when the station is connected.
- Clear entry button – removes the station, ie cancels the pairing. For the change to take effect, it is necessary to write the configuration to the controller.

#### Device mapping table:

In this table, the source devices of the station are assigned to the destination (logic) device of the controller. Each line defines one usable device. New mapping can be added by pressing the Add entry button. A maximum of 6 devices can be mapped in total.

- Station – in this field the remote station is selected from the station table.
- Device type – in this field the device type is selected. Since firmware version 3.2, the number of published source devices of a certain type is indicated in parentheses. If no number and brackets are displayed, then the remote station does not publish any source devices of this type.
- Source device – the source device is selected in this field. If the source device cannot be selected, then the station either does not publish any physical device for the type, or a map of available devices has not yet been retrieved from the station. The source devices are generally named with identical names as the respective inputs and outputs of the station.
- Direction – this field displays the direction of data flow between the source and destination devices. For input devices (binary input, temperature, power) the data is transferred from the source to the destination, for output devices (output) it is the other way around. For memory cells, the direction depends on what value is stored in it.
- Destination device – in this field the destination device is selected. If the destination device cannot be selected, then the controller (local unit) does not publish any logic device for that type. The destination (logic) devices are the following:
  - a) RI - remote binary input
  - b) RT - remote temperature input
  - c) RP - remote power meter
  - d) RV – remote voltage meter (since firmware version 3.2)
  - e) RO - remote output
  - f) M - memory cell
- Label – this field displays the label of the source device. These labels are also transmitted via the S-Connect protocol, with the exception of its wireless version (through SC-Gateway).

**Note:** The label can be filled in for the RO logic outputs in the output settings table in the same way as for the SSR outputs and relays. If the name is not filled in by the user, it is pre-filled with this source device label.

- Value – this field displays the current value of the source device that is transmitted via the S-Connect protocol. The value is displayed in the given units, the excitation in percent is displayed for the outputs.
- Ping – this field displays the response of the source device in milliseconds. The term response here means the cumulative response on the entire communication path from source to destination. If the source-destination communication does not take place via memory cells, but directly, the response of the device is equal to the response of the station. If memory cell communication is involved, then the device response is the sum of the responses of all participating stations.
- Device status indicator – is displayed in green when the device is connected and working.
- Clear entry button – removes the device, ie cancels the mapping. For the change to take effect, it is necessary to write the configuration to the controller.

If an invalid or duplicate mapping is stored by the user, then the controller will delete it itself after writing the configuration. Invalid mapping is that one where some data is not selected correctly. Duplicate mapping is that one where the same source output is used in 2 or more mappings or the same destination device is used in 2 or more mappings.

Input settings
Output settings
Time schedules
Other settings
S-Connect
Statistics
Log

Communication mode: access point (AP) v

Remote station table

Type	MAC address	Name	Config. name	Serial num...	IP address	LQI [%]	Msg. count	Ping [ms]	
wireless	0.21.141.0.0.10.8.34	WATTrouter Mx	TEST	46000001	0.0.0.0	67	2291	2260	<span style="color: green;">●</span> <span style="color: red;">✕</span>
wireless	0.21.141.0.0.23.104.168	Socket		00000000	0.0.0.0	35	2272	2270	<span style="color: green;">●</span> <span style="color: red;">✕</span>
unused	0.0.0.0.0.0.0.0			00000000	0.0.0.0	0	0	0	<span style="color: gray;">●</span> <span style="color: red;">✕</span>
unused	0.0.0.0.0.0.0.0			00000000	0.0.0.0	0	0	0	<span style="color: gray;">●</span> <span style="color: red;">✕</span>
unused	0.0.0.0.0.0.0.0			00000000	0.0.0.0	0	0	0	<span style="color: gray;">●</span> <span style="color: red;">✕</span>
unused	0.0.0.0.0.0.0.0			00000000	0.0.0.0	0	0	0	<span style="color: gray;">●</span> <span style="color: red;">✕</span>

Clear ignored stations

Device mapping table Add entry

Station	Dev. type	Src.device	Dir.	Dest.device	Label	Value	Ping [ms]	
Station 1 (WATTrou...)	output	R1	←	RO1		0 %	6390	<span style="color: green;">●</span> <span style="color: red;">✕</span>
Station 2 (Socket)	output	R1	←	RO2		0 %	2260	<span style="color: green;">●</span> <span style="color: red;">✕</span>

Figure 10: Example of access point configuration. 2 stations are paired, WATTrouter Mx equipped with a SC-Router module and a wireless socket. The device table maps 2 devices, 2 logic outputs RO1, RO2.

**Important information for input mapping**

If the device is not functional, or the corresponding mapping has been disconnected or canceled, then the default values are used for the respective input logic devices. They are:

- RI - logic 0 is used, ie input is disconnected.
- RT - temperature 0 °C is used.
- RP - power 0W is used.
- RV – voltage 0V is used.



### Important information for output mapping

For output logic devices, the physical outputs of the source (remote) station are mapped to the logic outputs of the destination (local) station. The destination outputs are abbreviated RO (previously these outputs were intended for wireless communication only and were abbreviated WLS). Within the SOLAR controls s.r.o. product range they can have different types and can have different functions assigned to them.

The supported output types in the current version of the S-Connect protocol are as follows:

- a) Relay - the output is an electromechanical relay. An example is the relay output of any wattrouter.
- b) PWM - semiconductor output that allows relay switching or pulse width modulation. An example is the Ext output of the Heating Control controller.
- c) SPC - semiconductor output that allows relay switching or zero switch proportional control. An example is the triac output of the Wattrouter M controller.
- d) PWM\_SPC - semiconductor output that allows relay switching, zero switch proportional control and pulse width modulation. An example is the SSR output of any wattrouter.

The output type is transmitted by the S-Connect protocol from the source (physical) to the destination (logic) device and can be used by the local unit to determine the compatibility of the given control algorithm with the respective output type.

**Caution:** *Not all devices support all types of outputs! For example, the Wattrouter Mx does not support the SPC type because it does not have built-in triacs like the Wattrouter M. In contrast, the Heating Control controller does not support SPC and PWM\_SPC outputs because it does not contain algorithms for proportional control. It is necessary to keep this in mind when expanding the number of outputs and selecting the appropriate expansion unit!*

The Wattrouter ECO controller fully distinguishes the output types and does not allow the user to activate such control algorithms that would not respect this. Wattrouter Mx also checks the validity of the received values for switching its outputs. If the received value for the relay output is different from the off and on state, the relay switches in slow pulse width modulation mode with a period of 10 minutes.

The supported output functions in the current version of the S-Connect protocol are as follows:

- a) Relay - the output can only be switched off or on.
- b) SPC - the output performs zero switch proportional control.
- c) PWM - the output switches in pulse width modulation mode.

The output function is transmitted by the S-Connect protocol from the destination (logic) device to the source (physical) device, and the source unit can use it to determine the switching algorithm of the output if the output allows multiple algorithms.

**Example 1:** *The source and destination units are both Wattrouter Mx. The source unit only provides output expansion for the destination unit, which provides basic control of PV excess energy. The source wattrouter uses the S-Connect protocol to inform the destination wattrouter that it has an SSR1 output, which is of the PWM\_SPC type, thus enabling 3 algorithms for switching. The user maps this output in the destination wattrouter to the logic output RO1 and all 3 functions (relay, continuous control, PWM) are displayed in the Function field of RO1. The user selects the function, eg proportional control. The function is transferred back to the source device via the S-Connect protocol, which will then switch the SSR1 output in proportional control mode.*

**Example 2:** *The source unit is Heating Control, the destination unit is Wattrouter Mx. The source unit only provides output expansion for the destination unit, which provides basic control of PV excess energy. The source wattrouter uses the S-Connect protocol to inform the target that it has an Ext1 output, which is of the PWM type, so it allows only 2 algorithms for switching (relay or PWM). The user maps this output in the destination*

watrouter to the logic output RO1 and only 2 functions (relay and PWM) are displayed in the Function field of RO1. The user selects the function, eg PWM. The function is transmitted back via the S-Connect protocol to the source device, which then switches the Ext1 output in pulse width modulation mode.

## STATISTICS TAB

**Note:** This function is only accessible with activated Statistics SW feature.

This tab displays daily, weekly, monthly and yearly statistics on production, consumption and surplus (excess) energy, as they were saved to internal EEPROM memory. Statistics can be exported to \*.csv files.



Through the current sensing module it is only possible to measure consumption and surplus data using IL1-3 signals. In order to display data on production and self consumption, it is necessary to add photovoltaic power measurements. As of firmware version 3.0, this means setting the appropriate input carrying active power information in the Production field in the Input settings for statistics on the Other settings tab. It is possible to use FB input for this. It is necessary to connect pulse output from an external electricity meter, which measures the power and energy from the inverter, to the FB input. Alternatively, connect inverter directly to the FB input when the inverter is equipped with a compatible impulse output.



**Values are approximate! The device does not know the exact values from utility/billing meters!**



Daily statistics are reset every time just after midnight, i.e. at 0:00 A.M. At the same time, daily values from the just finished day are moved into history. When you change the date in the controller you may cause irreversible deletion of stored history!

### Real time chart (since firmware version 1.7):

Up to 7 rows can be selected in this line chart, which can display power curves. You can select a time base of acquiring values from 1 second to 10 minutes. The maximum number of points on the time axis of the chart is 144 (when selecting a ten-minute period it corresponds to 1 day). The chart data are not stored in a non-volatile EEPROM, and therefore after a reset, or if there is a power failure, the data is deleted. The data will also be erased each time you reconfigure this chart.

- Time base - configure the period of reading values into the chart.
- Series 1-7 - dropdown menus configure the input or output to be loaded into the corresponding chart series. As of firmware version 3.0, if the S-Connect protocol is activated, any logic RO output can also be displayed in the chart.
- Export - exports chart data to a \*.csv file that can be opened e.g. in MS-Excel.

### Daily statistics:

- Show for day –select the date for which to view daily statistics. You can display them for current date and last 7 days.
- Phase Lx–displays information about the surplus (excess) energy, normal and low price energy tariff as well as (optionally) production, when counted with a FB input, in the current or selected day.
- Total L1+L2+L3 – displays summary data from all three phases. The calculation of these data depends on the selected control mode -the "Control settings" field on the "Input settings" tab:
  - a. Each phase independently – summary data are simply the sum of the fields from all 3 phases
  - b. Sum of all phases – summary data are updated continuously from immediate results. **In this control mode summary data are not the simple sum of the displayed values in each phase** (in one phase the surplus energy may cover consumption in different phase, etc.).

- Daily output status- displays the assumed amount of energy supplied to each load in the current or selected day. **Since the statistics are reset every time just after midnight, these values do not correspond with the values in the fields "Supplied energy"**(reset of those fields is generally done at different time).
- Daily FB input status- displays the measured energy at corresponding FB input in the current or selected day. If the FB input is configured to measure production then a short label "counts prod." appears above the measured value.
- Erase statistics – use this button to delete all statistics stored in the built-in EEPROM memory. Confirmation dialog will be shown first.
- Charts – they show a graphical interpretation of the daily statistics on production and consumption. Charts in each phase indicate the part of corresponding summary data (pie slice or part of the bar). The self-consumption value is calculated from the relationship: self-consumption = production – surplus energy. Self-consumption values are not available unless the displayed production value is bigger than measured surplus energy value.

**Note:** For very small energy values (typically immediately after resetting statistics after midnight) internal rounding to 0.01kWh is significant for displaying the charts .In these cases, pie charts may not be displayed absolutely correctly.

#### Weekly statistics:

- Chart -shows the 5 main summary data (production, surplus energy, self-consumption, consumption in normal and low tariff) in bars for the last 7 days. Double click on the bar to view the day in the daily statistics.

#### Monthly statistics:

- Production chart - displays summary data on production (production +surplus energy) in the last 31 days.
- Consumption chart - displays summary data on consumption (self-consumption, consumption in normal and low tariff) in the last 31 days.
- Export- exports monthly statistics to a \*.csv file that can be opened e.g. in MS-Excel. For first 7 days daily output and FB input states are exported from weekly stats.
- Import - imports monthly statistics from the \*.csv file. The file must contain monthly statistics stored in WATTconfig Mx, M, or ECO. This feature can transfer statistics from another device. The daily input and output states are not imported. This import replaces internal statistics.

**Note:** The monthly statistics can't show detail of a day as in the case of weekly statistics, details are stored only for the last 7 days.

#### Yearly statistics:

- Production chart – displays summary data on production (production +surplus energy) in the last 12 months.
- Consumption chart – displays summary data on consumption (self-consumption, consumption in normal and low tariff) in the last 12 months.
- Export- exports yearly statistics to a \*.csv file that can be opened e.g. in MS-Excel. Exports data for last 24 months.
- Import - imports annual statistics from the \*.csv file. The file must contain annual statistics stored in WATTconfig Mx, M, or ECO. This feature can transfer statistics from another device. This import replaces internal statistics.

**Note:** Actual day will take effect in the annual history (current month) after moving into history (after midnight).

#### LOG TAB

**This tab displays error and warning log.** For example, the system displays detected communication errors. Since firmware version 1.7, there is also a listing of up to 20 error messages stored in the controller from the

latest to the oldest. This error list is not stored in the nonvolatile memory (EEPROM) so that it is deleted in case of a power failure.

- Clear error list - press this button to clear the error list in the controller.
- Save error list - press this button to save the error list to a CSV file on your PC hard drive.
- Clear log – use this button to clear log contents.
- Save log – use this button to save the log as text file on your PC hard drive.
- Write detailed communication info - check this option to see more detailed information about communicating with the controller, for example for diagnostics. Additional information may help the technical support to detect possible problems in connection configuration etc.

---

## OPTIONS AND BUTTONS

### **Main window buttons:**

- Connect – connects your computer to the controller and loads configuration from the controller just after successful connection has been established.
- Disconnect - disconnects your computer from the controller.
- Configure connection - the software displays a window where you may configure active connection.
- Read – reads configuration from the controller.
- Write – writes (downloads) configuration to the controller and optionally resets the controller.
- Open - loads configuration from PC.
- Save - saves configuration to PC.
- Reset to defaults – loads default configuration settings.
- Exit - exits WATTconfig ECO software.

## USB/COM DRIVER CONFIGURATION WINDOW

In this dialog box you may specify USB interface parameters.

### Port settings:

- Port – if the USB driver correctly installed, you can find appropriate port COMx in drop – down menu. If several or no ports are shown, check installation correctness of USB port in Windows device manager. You can also find out there which port is used for this communication. The communication parameters are fixed: 38400 Bd, 8N1.

### Timeouts:

- Default read timeout – total time necessary to receive response from the controller. Modify the value (increase) only if you experience communication problems.

### Buttons:

- Default – sets default communication parameters.
- OK, Cancel – standard confirmation and cancellation of the dialog box.

## BUY ADDITIONAL FEATURES WINDOW

In this dialog box you may buy and activate additional (optional) software features.

- Additional features – shows available SW features including the price. In case of not listing the price, controller is missing internet connection or manufacturer's web is not accessible. In this case, you can continue neither in shopping nor in activation process of optional software features.
- User account login – is for signing in the personal profile created by customer at the producer web pages.
- Order – by this button you will create the order of selected SW features at the manufacturer's web pages. You will be redirected to web pages where you will be able to complete the order.
- Activate – once the order is paid and processed, you can activate your SW features in your controller.

### Complete the ordering and activation:

**Caution:** This procedure is necessary to be performed with one PC (notebook) and with the same instance of the software WATTconfig ECO. The PC must be free from any custom HTTP restriction or other user restrictions that would impede the connection of the software to the Internet and storage of temporary values to the hard disk. In case of problems, consult an expert in IT. Additional software features are bound to the serial number of the controller and they must be activated directly in the controller after purchase.

1. Connect your PC to the controller for a while, so its serial number can be detected.
2. Connect to the Internet (if the connection is not active) and open this dialog box (Buy additional features) in the running WATTconfig ECO. In it, enter the access data to the user profile on the manufacturer's website (if you do not have one, create one on the manufacturer's website), check the desired optional functions and press the Order button.
3. Once everything is OK, then new order is created at the manufacturer's website, which needs to be confirmed at this website. Then make a payment based on proforma invoice which will be sent to you by email.
4. Wait till final invoice will arrive to you by email. This may take couple of days, based on selected way of payment.
5. Open this dialog again, fill in your access data for your profile at the manufacturer's website and press button Activate. You need to use the same profile for activation as you used for purchase of additional software features.
6. If everything is correct, get connected to controller. Activation of purchased additional features will be done automatically. If the activation fails and purchased features are not available, you can repeat activation (point 5 and 6) at any time, or contact the manufacturer's technical support.

## LED STATUSES

The following table shows possible controller statuses indicated by built-in LEDs.

LED	Status	Note
LED PWR (green)	On	The controller is switched on and no output is active.
	Flashes	The controller is switched on and some outputs are active.
	Flashes quickly	The controller is switched on and boot mode is active.
	Off	The controller is without power supply or there is a failure.
LED COM (yellow)	Off	Communication with computer via USB was not established.
	Stays on or flashes quickly	Communication with computer via USB was established.
LED ERR (red)	Off	No error status detected.
	Flashes regularly in the following way: short- short- short	L1 voltage is missing. Proceed according to instructions specified in the chapter Measured parameters and statuses .
	Flashes regularly in the following way: long- long- short	DC source overload. Proceed according to instructions specified in the chapter Measured parameters and statuses.
LED OUT	Flashes regularly in the following way: long- short- short	S-Connect: device error. Proceed according to instructions specified in the chapter Measured parameters and statuses.
	Off	The relevant output is not active.
LED PWR (blue) under the lid of regulator.	On or flashes quickly	The output is active (switched on)
	Off	SC-Gateway module is not powered or module error.
	Flashes quickly	SC-Gateway module is being initialized after power on.
LED LINK (yellow) under the lid of regulator.	Flashes slowly	SC-Gateway module has been initialized and running.
	Off	No wireless communication.
	On or flashes quickly	Indicates wireless communication.

**CONFIGURATION EXAMPLES**

The examples below only illustrate the possible use of the device; in most cases it may be necessary to adjust the settings. The examples were created in version 1.1 of the software. In newer versions there may be other advanced options to further increase the efficiency of the system.

**EXAMPLE NO. 1 – ONE LOAD ONLY**

Boiler with nominal power rating of 2 kW, 200l of water, average cold water temperature at the input is 12 °C, warm water target temperature 50 °C, average daily water consumption is 160 l. The daily amount of electric power necessary to heat up the entire boiler (without taking into account heat losses) is:

$$E = \frac{c_v * V[l] * \Delta T[K]}{3600000} = \frac{4180 * 200 * 38}{3600000} = 8.82 \text{ kWh}$$

Average daily losses of boilers with these parameters represent approximately 1.5 kWh. If you use 160 l of warm water and you take into account heat losses, the daily supply of electric power is approximately 8.6 kWh.

Boiler is connected to SSR output No. 1, WATTrouter ECO device uses low tariff signal and the boiler operates under CombiWATT mode.

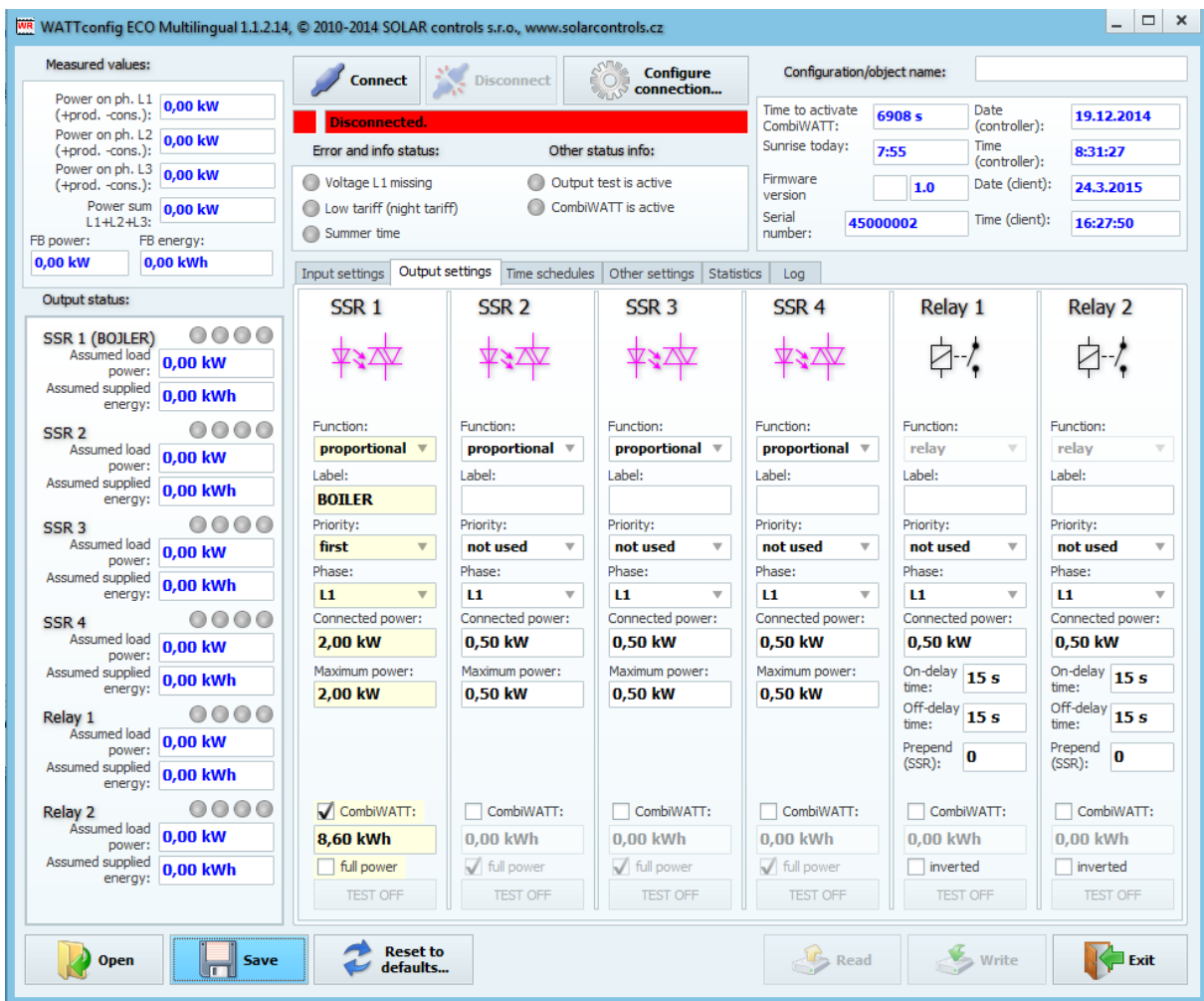



The time schedule is configured for the boiler between 15:00 and 19:00. It becomes active only if the low tariff is available. This allows you to heat up water for evening use, provided that during morning and afternoon hours the boiler was not sufficiently heated up by power supplied by the PV-plant. If low tariff is not active, the basic control mode according to available surplus energy continues even during this time period.

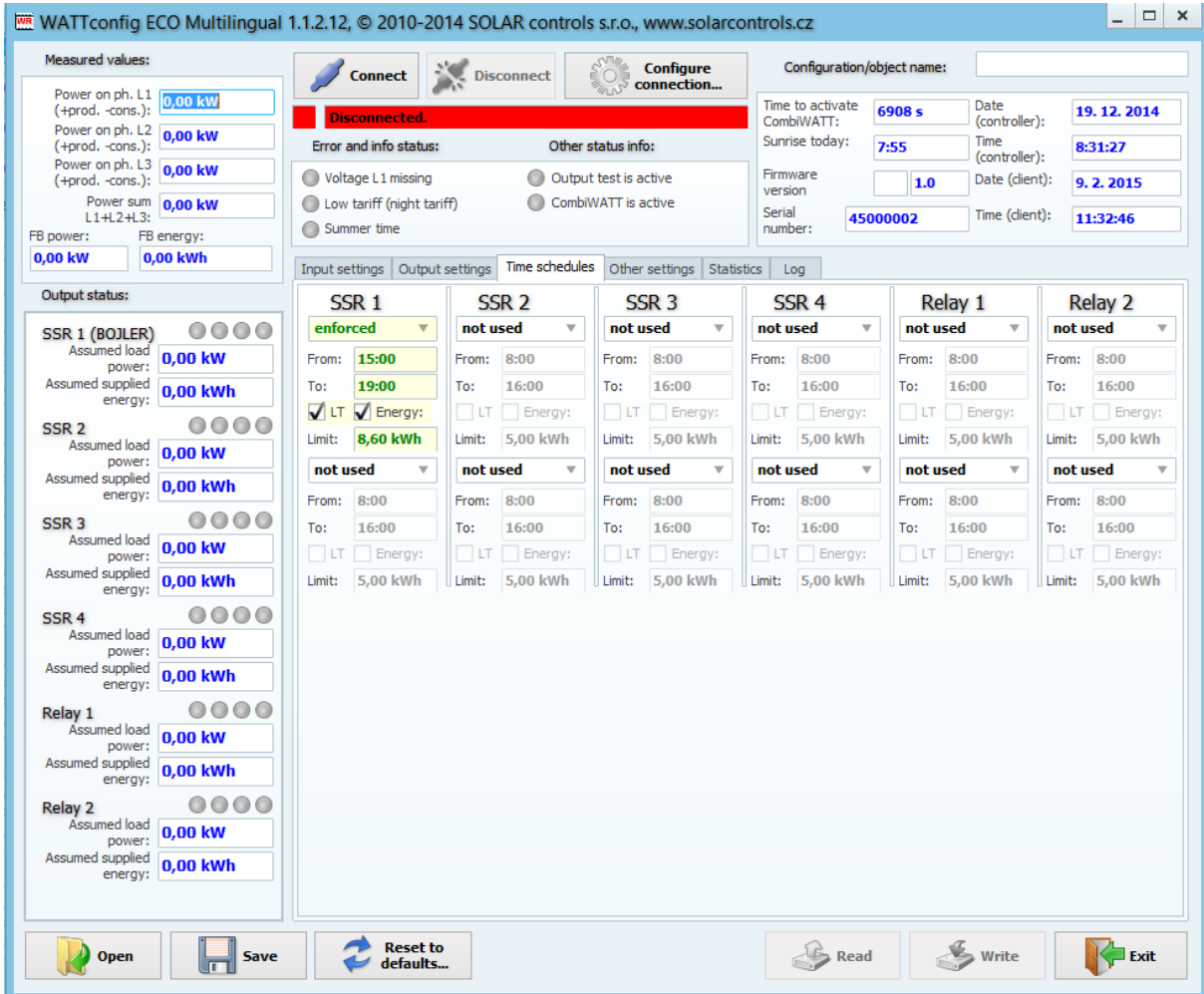

WATTconfig ECO Multilingual 1.1.2.12, © 2010-2014 SOLAR controls s.r.o., www.solarcontrols.cz

Measured values:

- Power on ph. L1 (+prod., -cons.): 0,00 kW
- Power on ph. L2 (+prod., -cons.): 0,00 kW
- Power on ph. L3 (+prod., -cons.): 0,00 kW
- Power sum L1+L2+L3: 0,00 kW
- FB power: 0,00 kW
- FB energy: 0,00 kWh

Connect Disconnect Configure connection...

Configuration/object name:

Time to activate CombiWATT: 6908 s Date (controller): 19. 12. 2014

Sunrise today: 7:55 Time (controller): 8:31:27

Firmware version: 1.0 Date (client): 9. 2. 2015

Serial number: 45000002 Time (client): 11:32:46

Error and info status: Other status info:

- Voltage L1 missing
- Output test is active
- Low tariff (night tariff)
- CombiWATT is active
- Summer time

Input settings Output settings Time schedules Other settings Statistics Log

SSR 1	SSR 2	SSR 3	SSR 4	Relay 1	Relay 2
enforced	not used	not used	not used	not used	not used
From: 15:00	From: 8:00	From: 8:00	From: 8:00	From: 8:00	From: 8:00
To: 19:00	To: 16:00	To: 16:00	To: 16:00	To: 16:00	To: 16:00
<input checked="" type="checkbox"/> LT <input checked="" type="checkbox"/> Energy:	<input type="checkbox"/> LT <input type="checkbox"/> Energy:	<input type="checkbox"/> LT <input type="checkbox"/> Energy:	<input type="checkbox"/> LT <input type="checkbox"/> Energy:	<input type="checkbox"/> LT <input type="checkbox"/> Energy:	<input type="checkbox"/> LT <input type="checkbox"/> Energy:
Limit: 8,60 kWh	Limit: 5,00 kWh	Limit: 5,00 kWh	Limit: 5,00 kWh	Limit: 5,00 kWh	Limit: 5,00 kWh
not used	not used	not used	not used	not used	not used
From: 8:00	From: 8:00	From: 8:00	From: 8:00	From: 8:00	From: 8:00
To: 16:00	To: 16:00	To: 16:00	To: 16:00	To: 16:00	To: 16:00
<input type="checkbox"/> LT <input type="checkbox"/> Energy:	<input type="checkbox"/> LT <input type="checkbox"/> Energy:	<input type="checkbox"/> LT <input type="checkbox"/> Energy:	<input type="checkbox"/> LT <input type="checkbox"/> Energy:	<input type="checkbox"/> LT <input type="checkbox"/> Energy:	<input type="checkbox"/> LT <input type="checkbox"/> Energy:
Limit: 5,00 kWh	Limit: 5,00 kWh	Limit: 5,00 kWh	Limit: 5,00 kWh	Limit: 5,00 kWh	Limit: 5,00 kWh

Open Save Reset to defaults... Read Write Exit

**EXAMPLE NO. 2 – ALL 6 LOADS, CONTROL MODE - SUM OF ALL PHASES**

The same boiler as specified in example No. 1, swimming pool filtering pump and 6 kW instantaneous water heating for the swimming pool (pump and three-phase heating element). Recommended peak power output of the PV-plant is more than 8 kWp.

Boiler heating process has 1st priority (SSR No. 1). Requirements are the same as in example No. 1.

Filtering pump has 2nd priority (relay No. 1), nominal motor rating 0.3 kW (value in VA is usually not specified here), and it must run exactly for 6 hours per day and the minimum switching time is 5 minutes. The daily amount of required power for this motor is 1.8 kWh. If there is not sufficient amount of sunshine available, the system will use the low tariff. The motor should not be running at night between 23:00 and 5:00 - not to disturb during night (this also depends on the local low tariff time schedule so that the motor can get a chance to run).

Pump for heating has 3rd priority (relay No. 2), power output 0.16 kW and it must always run if the heating element of the pool heating is on. The typical off delay time for the pump is 1 minute. We only want to turn the swimming pool heating when there is surplus energy available. Make sure swimming pool heating is fitted with a thermal protection! Heating elements are connected to the remaining outputs with lower priorities (rest of SSR outputs).

We recommend using separate contactors for motors, but due to their low power consumption rate it is not really necessary. WATTrouter ECO device uses low tariff signal and the boiler and swimming pool filtration motors operate under CombiWATT mode.

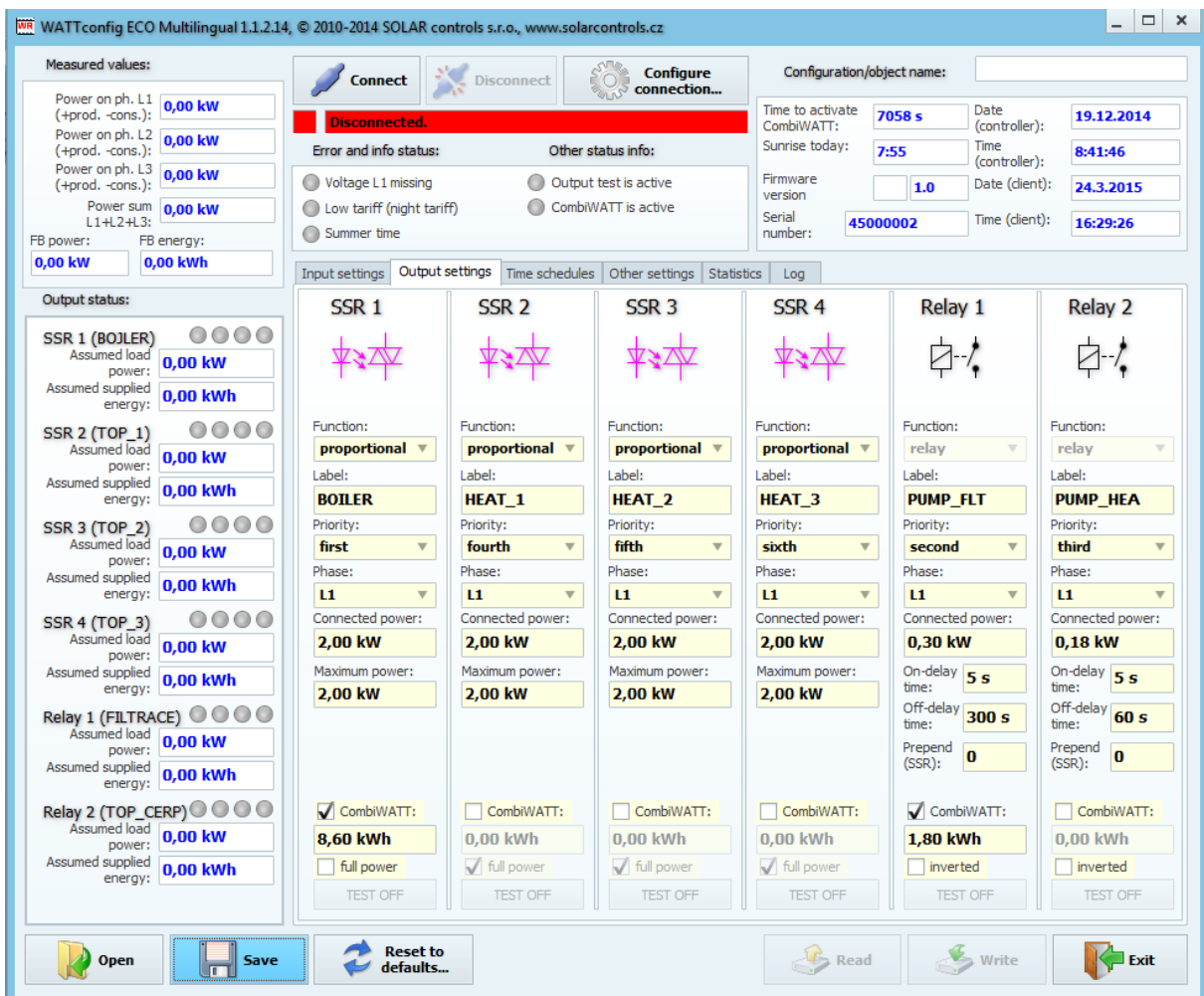

Time schedule for boiler is set the same as in example No. 1.

Two time schedules are assigned for pool filtering pump. The first of them describes restriction of the output during "daytime" between 8:00 and 23:00. This restriction ensures the motor runs approximately 6 hours and therefore, it applies only if the daily energy counter exceeds 1.8 kWh. The second time schedule restricts operation of the motor between 23:00 and 5:00 without any special requirements or conditions. The necessary prerequisite for correct application of these two time schedules is correct configuration of daily energy counter reset. As reset mode there must be selected "at sunrise" or "at fixed time". The fixed time for second case should be selected in the morning before 8:00.

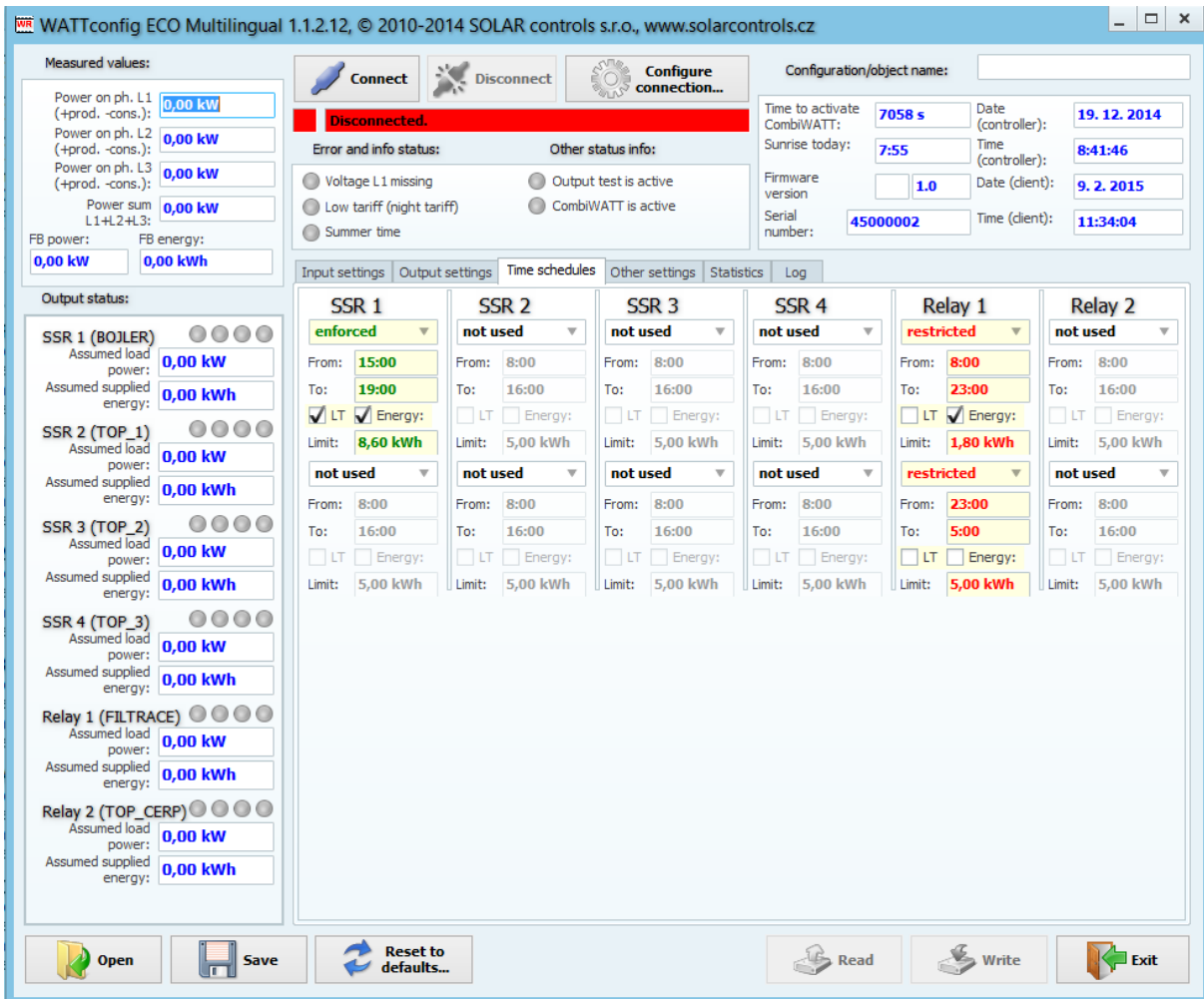

**EXAMPLE NO. 3 – ALL 6 LOADS, CONTROL MODE - EACH PHASE INDEPENDENTLY**

Loads specified in example No. 2 but more complex connection. Control mode is set for each phase independently.

Connect the following to L1 phase:

- boiler has 1st priority (SSR 1 No. 1), requirements are the same as in example No. 1.
- pool filtering pump has 2nd priority (relay No. 1), requirements are the same as in example No. 2.

Connect the following to L2 phase:

- pump for heating has 1st priority (relay No. 2), requirements are the same as in example No. 2.
- one heating coil with 2nd priority (SSR 2).

Connect the following to L3 phase:

- auxiliary contact with 1st priority (SSR 3 operating as a relay), will also turn on the circulation pump connected actually to phase L2 (here, a small amount of power may be drawn from the public grid at phase L2, but in order to prevent it we would have to use two circulation pumps).
- 2nd heating coil with 2nd priority (SSR 4).

Unfortunately, in this "one-regulator" configuration setup, the 3rd heating coil cannot be connected. We would have to make sure that the circulation heat pump will be turned on by one output only - using a time schedule, or completely separately - outside of WATTrouter.

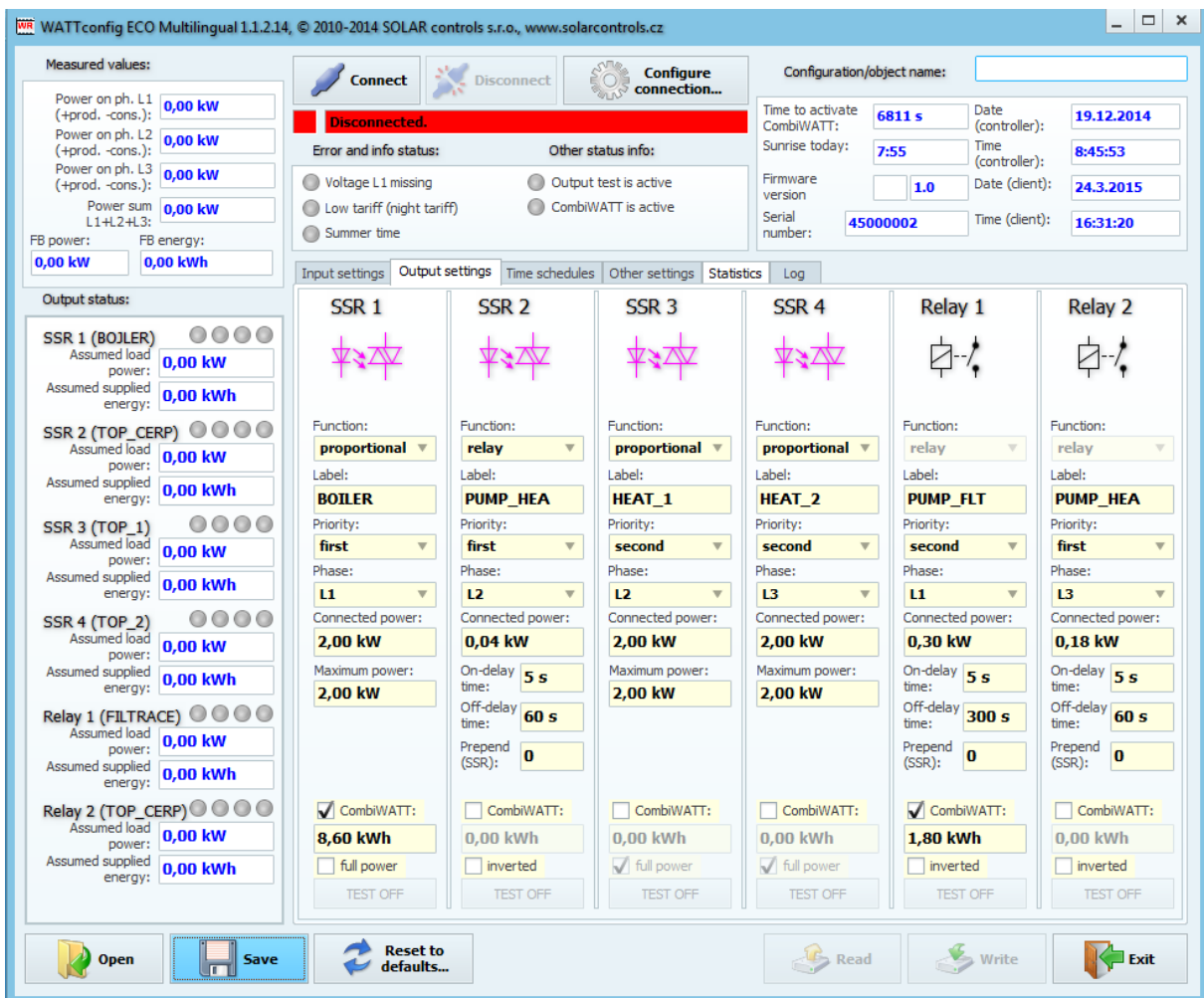

Time schedules are the same as in example No. 2.

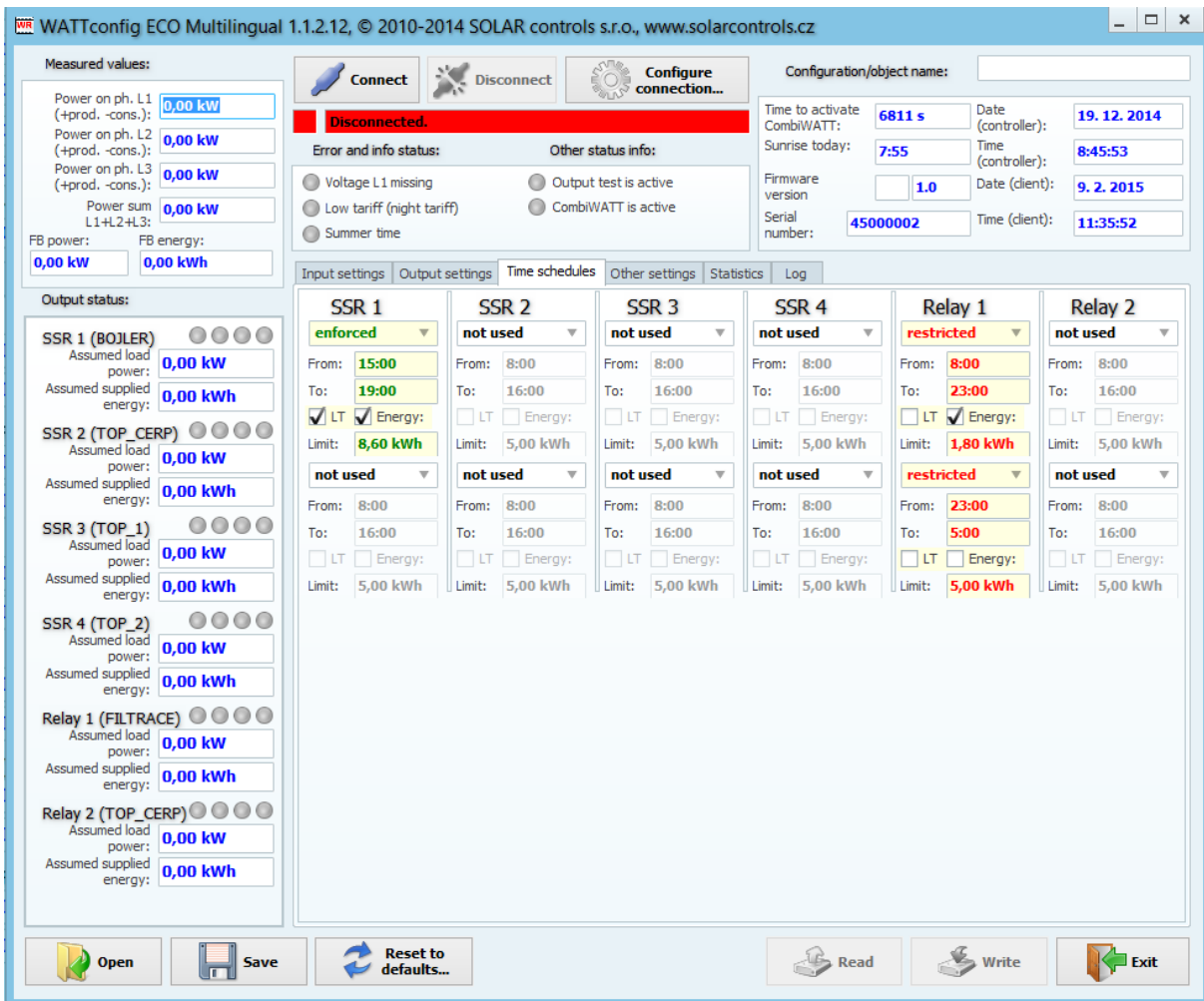

The screenshot shows the 'WATTrouter ECO Multilingual 1.1.2.12' software interface. The main window is titled 'Configuration/object name:'. The interface is divided into several sections:

- Measured values:** Displays power on ph. L1, L2, L3, and Power sum L1+L2+L3, all showing 0,00 kW. It also shows FB power and FB energy, both at 0,00 kW and 0,00 kWh.
- Connect/Disconnect/Configure connection...:** Buttons for system control. The status is 'Disconnected'.
- Error and info status:** Shows 'Error and info status: Disconnected' in a red banner. Below are radio buttons for 'Voltage L1 missing', 'Low tariff (night tariff)', 'Summer time', 'Output test is active', and 'CombiWATT is active'.
- Configuration/object name:** A text field for naming the configuration.
- Time to activate:** 6811 s.
- Date (controller):** 19. 12. 2014.
- Time (controller):** 8:45:53.
- Sunrise today:** 7:55.
- Date (client):** 9. 2. 2015.
- Time (client):** 11:35:52.
- Firmware version:** 1.0.
- Serial number:** 45000002.

The main configuration area is titled 'Time schedules' and contains a table of settings for SSRs and Relays:

SSR 1	SSR 2	SSR 3	SSR 4	Relay 1	Relay 2
enforced	not used	not used	not used	restricted	not used
From: 15:00	From: 8:00	From: 8:00	From: 8:00	From: 8:00	From: 8:00
To: 19:00	To: 16:00	To: 16:00	To: 16:00	To: 23:00	To: 16:00
<input checked="" type="checkbox"/> LT <input checked="" type="checkbox"/> Energy:	<input type="checkbox"/> LT <input type="checkbox"/> Energy:	<input type="checkbox"/> LT <input type="checkbox"/> Energy:	<input type="checkbox"/> LT <input type="checkbox"/> Energy:	<input type="checkbox"/> LT <input checked="" type="checkbox"/> Energy:	<input type="checkbox"/> LT <input type="checkbox"/> Energy:
Limit: 8,60 kWh	Limit: 5,00 kWh	Limit: 5,00 kWh	Limit: 5,00 kWh	Limit: 1,80 kWh	Limit: 5,00 kWh
not used	not used	not used	not used	restricted	not used
From: 8:00	From: 8:00	From: 8:00	From: 8:00	From: 8:00	From: 8:00
To: 16:00	To: 16:00	To: 16:00	To: 16:00	To: 5:00	To: 16:00
<input type="checkbox"/> LT <input type="checkbox"/> Energy:	<input type="checkbox"/> LT <input type="checkbox"/> Energy:	<input type="checkbox"/> LT <input type="checkbox"/> Energy:	<input type="checkbox"/> LT <input type="checkbox"/> Energy:	<input type="checkbox"/> LT <input type="checkbox"/> Energy:	<input type="checkbox"/> LT <input type="checkbox"/> Energy:
Limit: 5,00 kWh	Limit: 5,00 kWh	Limit: 5,00 kWh	Limit: 5,00 kWh	Limit: 5,00 kWh	Limit: 5,00 kWh

At the bottom of the interface, there are buttons for 'Open', 'Save', 'Reset to defaults...', 'Read', 'Write', and 'Exit'.

**EXAMPLE NO. 4 – 5 LOADS, CONTROL MODE - EACH PHASE INDEPENDENTLY**

Boiler and pool filtering system specified in example No. 2 plus 2 resistive electric heaters and a heat pump used to heat the swimming pool. Everything in more complex connection plus control mode set for each phase separately.

Each electric heater draws 2 kW and should be supplied only with the surplus energy, independently of the household primary heating system. These heaters must be deactivated at summer time - either through built in thermostats, by deactivating fuse switches for respective outputs or by deactivating them in the software.

The heat pump draws power of 1.3 kW and it is supplied only with the surplus energy, or manually, outside of the WATTrouter device.

Connect the following to L1 phase:

- boiler has 1st priority (SSR 1 No. 1), requirements are the same as in example No. 1.
- pool filtering pump has 2nd priority (relay No. 1), requirements are the same as in example No. 2.

Connect the following to L2 phase:

- 1st electric heater with 1st priority (SSR 2).
- heat pump with 2nd priority (relay No. 2).

Connect the following to L3 phase:

- 2nd electric heater with 1st priority (SSR 3).

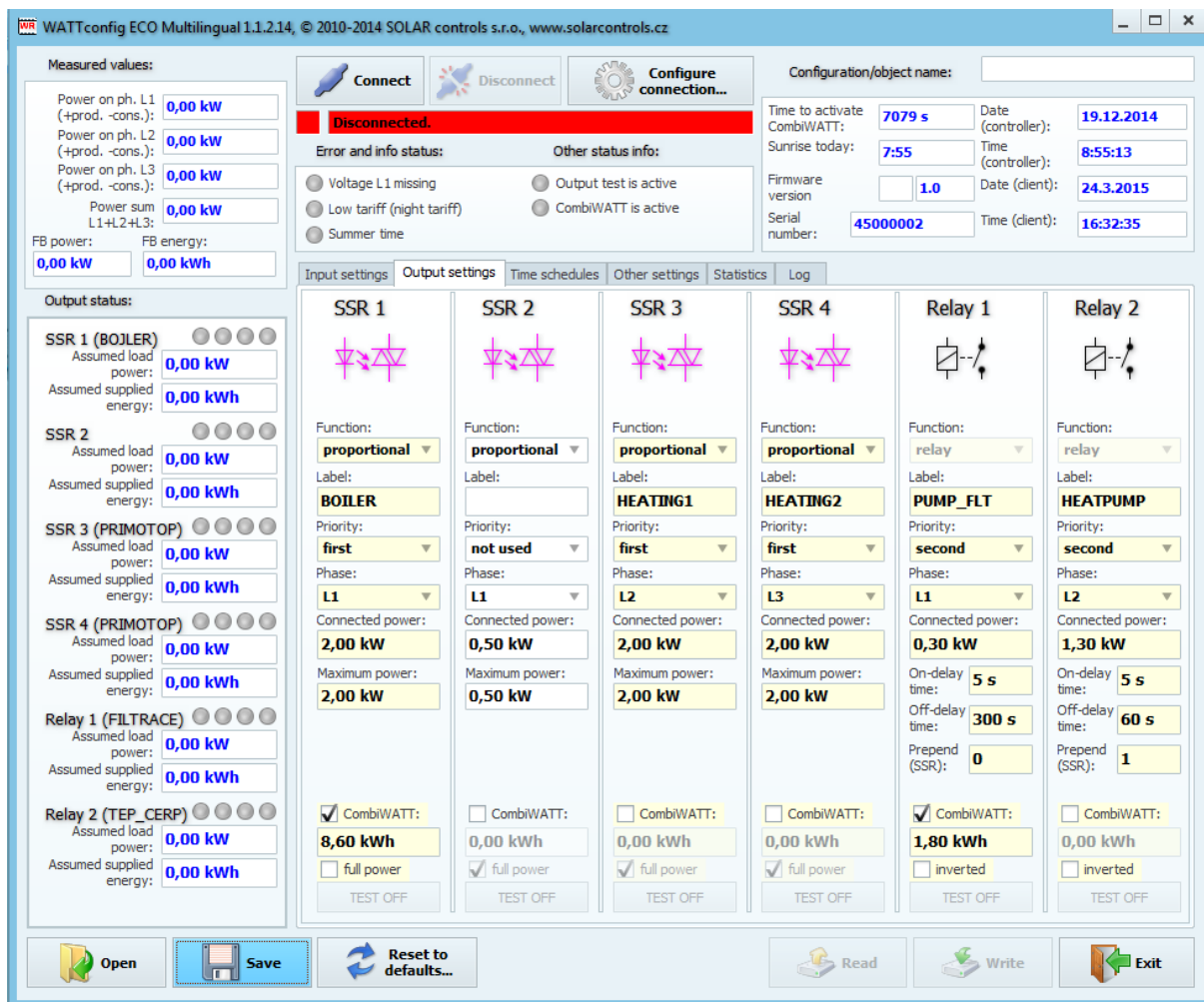

Time schedules are the same as in example No. 2.

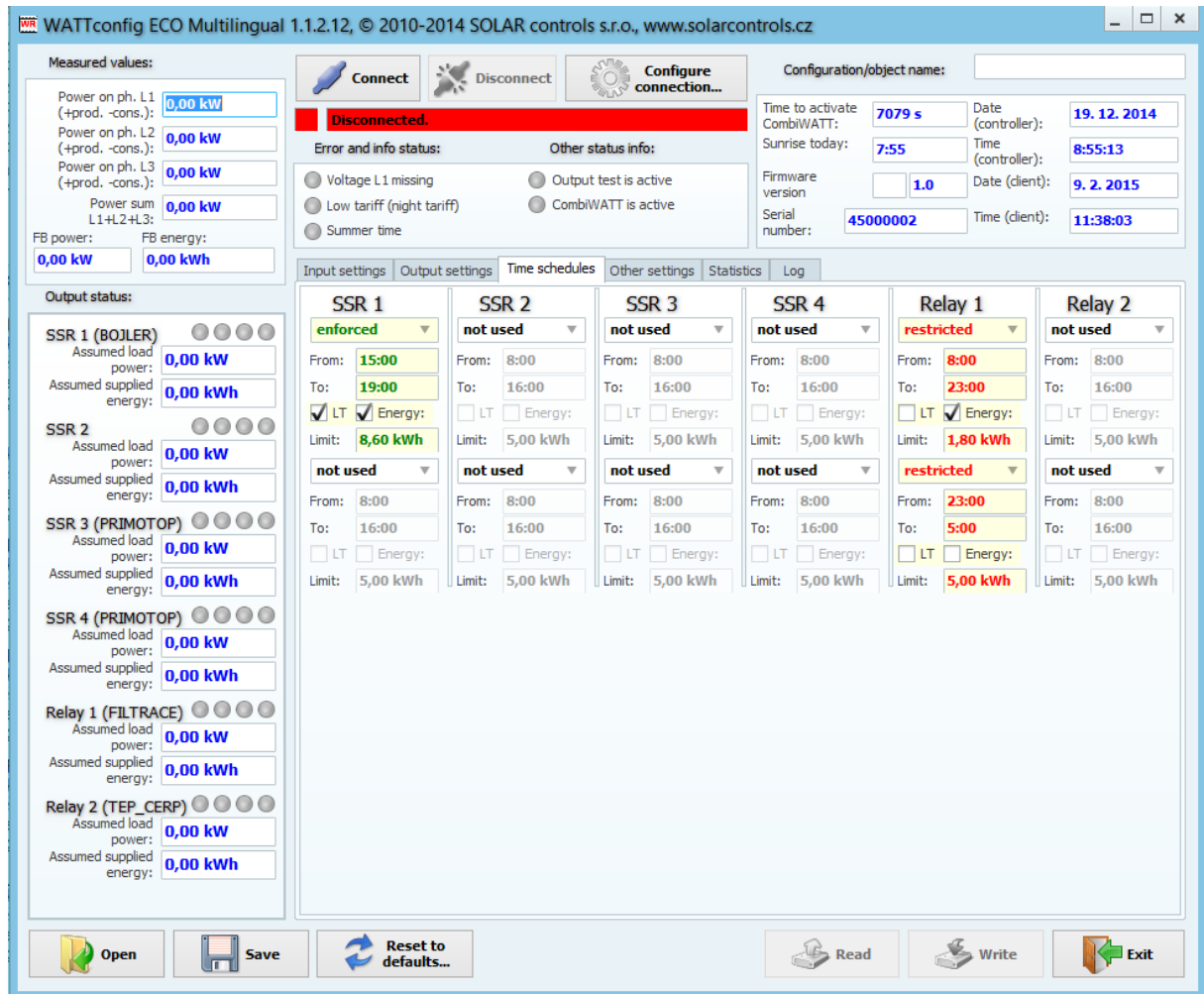

The screenshot displays the 'WATTrouter ECO Multilingual 1.1.2.12' configuration software. The interface is divided into several sections:

- Measured values:** Shows power on phases L1, L2, and L3, and power sum, all at 0,00 kW. It also shows FB power and energy at 0,00 kW and 0,00 kWh.
- Connect/Disconnect/Configure connection...:** The system is currently **Disconnected**.
- Error and info status:** Lists various error conditions like 'Voltage L1 missing', 'Low tariff (night tariff)', and 'Summer time', along with 'Other status info' like 'Output test is active' and 'CombiWATT is active'.
- Configuration/object name:** A text field for naming the configuration.
- Time to activate CombiWATT:** Set to 7079 s, with a date of 19.12.2014.
- Sunrise today:** 7:55, with a time of 8:55:13.
- Firmware version:** 1.0, with a date of 9.2.2015.
- Serial number:** 45000002, with a time of 11:38:03.
- Time Schedules:** A grid showing schedules for SSR 1-4 and Relay 1-2.
 

Device	Status	From	To	Limit	LT	Energy
SSR 1	enforced	15:00	19:00	8,60 kWh	<input checked="" type="checkbox"/>	<input checked="" type="checkbox"/>
SSR 2	not used	8:00	16:00	5,00 kWh	<input type="checkbox"/>	<input type="checkbox"/>
SSR 3	not used	8:00	16:00	5,00 kWh	<input type="checkbox"/>	<input type="checkbox"/>
SSR 4	not used	8:00	16:00	5,00 kWh	<input type="checkbox"/>	<input type="checkbox"/>
Relay 1	restricted	8:00	23:00	1,80 kWh	<input type="checkbox"/>	<input checked="" type="checkbox"/>
Relay 2	not used	8:00	16:00	5,00 kWh	<input type="checkbox"/>	<input type="checkbox"/>
- Output status:** Lists assumed load power and assumed supplied energy for SSR 1-4 and Relay 1-2, all showing 0,00 kW and 0,00 kWh.
- Bottom Bar:** Contains buttons for Open, Save, Reset to defaults..., Read, Write, and Exit.

## DESCRIPTION OF THE S-CONNECT PROTOCOL

The S-Connect protocol allows you to share devices via any physical network communication layer. The SOLAR controls s.r.o. controllers currently support device sharing via 2 physical layers:

- a) Over the existing network architecture, ie Ethernet or WIFI. This is only possible if the device is connected to an Ethernet network. Therefore, it cannot be used for WATTrouter ECO.
- b) Over the wireless architecture which is created by the SC-Gateway module. This is only possible if a SC-Gateway or SC-Router module is inserted in the device. Therefore, it cannot be used for WATTrouter M and Heating Control.

**Attention:** In the case of ad a) communication is provided by UDP and TCP protocols. Regarding the requirements for the UDP protocol, see chapter Automatic pairing of stations to the access point. Port 50160 is used for TCP communication. For communication to work, this port must not be blocked on the network. In order for the communication to work without problems, the local network must not be excessively overloaded with other communication, eg by downloading large files, videos, etc.

**Attention:** Communication in case of ad a) is not secured. It may take place only in the local network or in a network that is sufficiently secured against unauthorized access!

**Attention:** Communication in case of ad b) only transmits information about the status of the outputs, due to limited data throughput. Therefore, the states of the inputs (binary inputs, temperatures, powers, etc.) and the states of the memory cells are not transmitted!

**Note:** The S-Connect protocol is not public, so only the principles of the protocol are described, not the protocol itself.

As of firmware version 3.2, the S-CONNECT 2 protocol is implemented, which is fully compatible with the first version of the protocol in terms of data exchange. In addition, the S-CONNECT 2 protocol can respond to a manual station pairing request from the access point.

The term device means hardware device that a controller supports and that holds certain status information, or measure certain physical quantities.

The S-Connect protocol allows you to transfer information from the following devices:

- a) Memory. The memory cell status is transferred. The memory cell can hold any status information described in the previous points.
- b) Output. The output excitation data in the range of 0 to 1000 is transmitted, where 0 means the output is switched off and 1000 means the output is fully switched on. In addition, some auxiliary data is transmitted, such as the output hardware type, the assigned output function, or the possible output restriction.
- c) Binary input. Status information 0 (off) or 1 (on).
- d) Temperature. The temperature data is transmitted with a resolution of 0.1 ° C.
- e) Performance. The instantaneous active power data with a resolution of 1W is transmitted. In addition, some auxiliary data is transmitted, such as the daily and total energy measured by the respective device.
- f) Voltage (since S-CONNECT 2). The electric voltage value with a resolution of 0.1 V is transmitted.
- g) Current (since S-CONNECT 2). The electric current value with a resolution of 1mA is transmitted.
- h) Generic (since S-CONNECT 2). The generic value is transmitted. This device type is intended for other, less frequently used physical quantities.

The S-Connect protocol works based on the access point's communication with remote stations, similar to how computers connect to a WIFI access point. The access point is always 1 device that the user chooses.



The access point controls the communication with remote stations and their pairing. There cannot be 2 access points in one S-Connect network, but there can be several S-Connect networks, ie several access points, within a local Ethernet network.

**Example 1:** A typical example of an access point is the Watrouter Mx controller, which provides power measurement on phases L1 to L3 and also switches the connected appliances (loads) according to the photovoltaic excess energy. Another Watrouter Mx controller is then connected to it as a remote station, which only serves as an output expansion module. The S-Connect protocol is transmitted via the Ethernet network.

**Example 2:** Another example of an access point is the Heating Control controller, which controls the building heating. The Watrouter Mx controller then connects to it as a remote station and shares information about the low tariff, temperature data, or excitation of the output needed to optimize the operation of a heat pump according to the photovoltaics excess energy (heat pump that is connected to Heating Control). The S-Connect protocol is transmitted via the Ethernet network.

**Example 3:** Another example of an access point is again the Watrouter Mx controller, which provides power measurement on phases L1-L3 and switches the connected appliances and at the same time it has the SC-Gateway module installed. A wireless socket is then connected to it as a remote station. The S-Connect protocol is transmitted over the wireless network and replaces the older protocol used in previous firmware versions for this wireless communication.

## AUTOMATIC PAIRING OF STATIONS TO THE ACCESS POINT

If the station is not connected to an access point, it sends a pairing request. This request is implemented differently depending on the physical layer used:

- a) Ethernet connection (for devices directly supporting S-CONNECT): The station sends a request periodically every 10 s. The station sends a UDP broadcast, which the access point receives if it is connected to the same local network. This UDP broadcast uses IP 255.255.255.255 and port 50161. For the request to arrive, this port must not be blocked on the network and the UDP broadcast function must not be blocked either.
- b) Ethernet connection (for devices that do not support S-CONNECT, connected via a bridge - see chapter Bridges to other protocols): The station sends a request periodically, usually every minute. The station sends an ARP broadcast (ARP announcement), which is received by the access point if it is connected to the same local network.
- c) Wireless connection: The station registers in the wireless network managed by the SC-Gateway module and the request is then sent from the SC-Gateway module to the unit to which the module is connected and which always acts as an access point. The wireless device must be within range of the SC-Gateway for the request to arrive. If the request does not arrive and even after a longer period of time (1 minute or more) and the information below is not displayed, then the station is probably out of range. Then proceed according to chapter Troubleshooting. The request arrives only once, to show the request again station restart is needed (switch it off and on again).

The station pairing request is then displayed to the user in the access point control interface, and the user must decide whether or not to allow the station to pair with the access point.

The pairing request then looks like this:

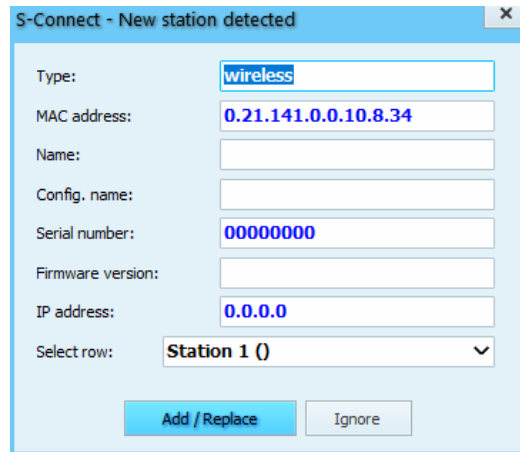

Figure 11: A dialog box showing the new station pairing request.

The user can then acknowledge the request and add the station to the specified row of the station table or reject the request, then add the station to the internal list of ignored stations so that the next time the access point ignores its repeated request.

To confirm the pairing or reject the station, it is necessary to write the configuration to the controller.

As soon as a station is added to the station table of the access point, the access point starts communicating with that station immediately.

This is also reflected in the station control interface, where the given access point appears in the first row of the station table.

This completes the pairing.

**Note:** In the case of ad a), if the connection between the station and the access point is interrupted, the station will start transmitting pairing requests again periodically. This is because the connection may have been lost due to a change in the station's IP address if, for example, the station uses DHCP for IP assignment. The pairing request is therefore also used to communicate the current valid IP address of the station to the access point.

**Note:** In case of ad a), if there are more access points in one local network, ie more independent S-Connect networks, the pairing request will be displayed in all access points. The user can try to pair the station with multiple access points, but communication can only take place with only one access point at a time, depending on where the first pairing took place. If a station has a specific access point assigned to it, it will refuse to communicate with another access point. Pairings with other access points will be invalid. If a pairing request is displayed at an access point where you do not want to pair the station, the request must be rejected, and the access point will continue to ignore that station.

## MANUAL PAIRING OF STATIONS TO THE ACCESS POINT

Since firmware version 3.2, it is also possible to pair individual stations manually on the Ethernet line (in accordance with the S-CONNECT 2 protocol). This form of pairing is only available for stations connected to an Ethernet line and may be necessary if there are too many different stations on the line or the internal table of ignored stations becomes full.

Manual pairing takes place using the UDP protocol on port 50160. This port must not be blocked on the network for the request to arrive.

In manual pairing mode, the IP address of the station is entered and the access point tries to find it on the network. Once the station is found, the pairing process is the same as in automatic pairing mode. For more detailed information on manual pairing, see the S-Connect tab chapter.

The manual pairing mode will only work for stations directly supporting the S-CONNECT 2 protocol, or for stations connected via one of the bridges (see chapter Bridges to other protocols).

### CANCEL STATION PAIRING

If the pairing needs to be canceled, this is done in the control interface of the access point and possibly the station.

For an access point, the appropriate command (Clear entry button) removes the stations from the access point station table. This will also delete the station from the access point, end the communication and delete all mapped devices from the device mapping table.

The access point remains assigned in the station control interface. It can either be deleted in the same way or left in case we want to re-pair this station with the same access point later.

### DEVICE PAIRING

After pairing the station with the access point, in order to share the device, it is necessary to assign the source (physical) devices of the remote unit to the destination (logic) device of the local unit. This assignment is called mapping and can be done both in the user interface of the access point and at the station.

Source devices can be selected from the device map, which is transmitted by the respective remote unit. The destination devices can be selected from the available logic devices of the local unit.

The mapping is performed in a device mapping table, where each row of the table maps one source device to one destination device. The principle of mapping is best illustrated by the following figure:

## S-CONNECT - a device sharing protocol

\*) local control

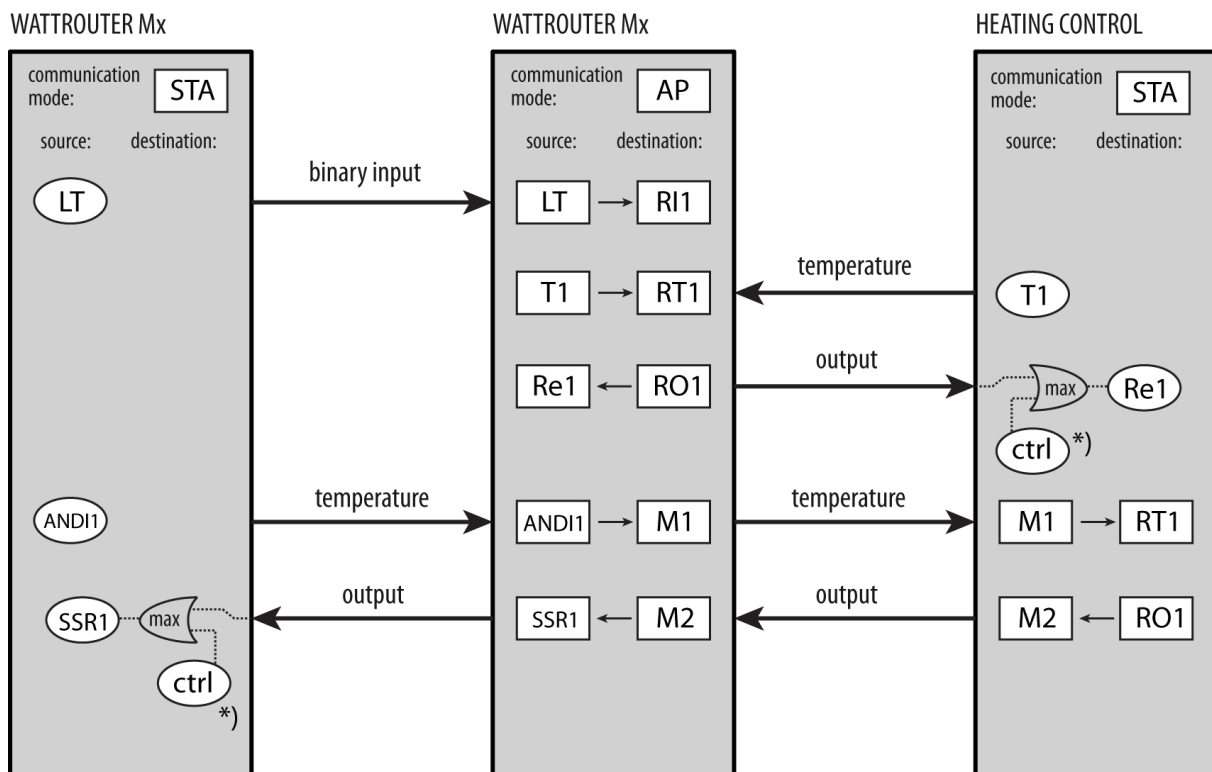

Figure 12: Device sharing in the S-Connect protocol. The communication mode of the given device is marked in the upper part, the relevant mappings of source devices to destination devices are marked in the rectangular fields below. The oval fields indicate the source physical devices available in the device. To excite (switch) the physical outputs, the maximum excitation of the local control of

the given device and the excitation received from the remote station is always used. The figure also shows the sharing of devices between individual stations using the memory cells of the access point.

Only after the mapping is completed, logic (remote) devices can be used in the local unit. These can be selected in various places in the control interface of the local unit as well as their physical devices.

## BRIDGES TO OTHER PROTOCOLS

Bridges to other protocols are not implemented due to the lack of an Ethernet interface.

## PROTOCOL LIMITATIONS IN THE WATTROUTER ECO

The S-Connect protocol has the following limitations in the device:

- Only wireless protocol version is available, only wireless stations can be connected.
- The wireless protocol version only works with the inserted SC-Gateway or SC-Router.
- Only remote outputs can be mapped due to limited data throughput. Therefore, the states of the inputs (binary inputs, temperatures, powers) and the states of the memory cells are not transmitted.
- Only RO logic outputs are available.
- There are no features related to the Ethernet interface, i.e. manual pairing of stations, bridges to other protocols (Tasmota API, Shelly API), etc.

## TROUBLESHOOTING

The following table shows the most frequent problems and usual solutions:

Problem description	Possible causes	Solution
<b>The controller has been fitted according to the manual but after you switch on the circuit breaker no LED lights up or flashes.</b>	The circuit breaker is on but the supply voltage is missing.	Check or measure whether there is any voltage between terminals L and N.
	Regulator failure/defect	Replace the regulator or take it to repair.
<b>The controller has been fitted according to the manual but after you turn on the circuit breaker the green LED quickly flashes, the controller does not work and the WATTconfig ECO software shows all zeros.</b>	The controller runs in the boot mode without any application firmware	Use the WATTconfig software and load the newest firmware version or load the version you prefer
<b>The controller does not communicate with computer</b>	The regulator has no voltage	Check whether green LED PWR is on and the regulator is powered.
	Computer is not properly connected with the controller	Check the USB cable connection, try using different network cable, or try the cable with different device (printer for example).
	Computer cannot detect connected controller.	Check USB cable connection. When USB device is being registered in your PC, the yellow LED COM must flash temporarily.
	USB interface driver was not correctly installed in your computer	Make sure the USB interface driver is correctly installed and Windows device manager detects it as a USB serial converter and USB serial port.
	USB interface driver is not configured properly	Use the USB/COM interface driver configuration window in WATTconfig ECO and reset all parameters back to default values and choose correct port.
	The Log window records communication errors	A very few communication errors is considered a common status and it depends on the actual load put on the operating system in your computer or on the operating system running in the controller or disturbance on communication line. However, if there are many errors inspect the functionality of your PC, or it may also be a conflict at the USB interface in your PC.
	Regulator failure/defect	Replace the regulator or take it to repair.
<b>Measured powers are not displayed or they are displayed incorrectly</b>	The current sensing module is not connected	Connect the current sensing module according to this manual.
	Incorrect phase sequence	Make sure that for all ILx inputs the "Phase" field is correctly set. Perform the settings

		according to chapter Setting up main function and check with Input checking oscilloscope.
	Incorrect current orientation settings	Make sure that for all ILx inputs the "Current orientation" field is correctly set. Perform the settings according to chapter Make sure that for all ILx inputs the "Current orientation" field is correctly set. Perform the settings according to chapter.
	Regulator or current sensing module defect	Replace the regulator and/or current sensing module or take them to repair.
<b>There are suspicious waveforms shown in chart "Input checking oscilloscope"</b>	This is normal	During normal operation there may be shown even "exotic" waveforms. Be sure this is the real current flowing through the phase wire, a superposition of currents flowing through the connected appliances which are not sinusoidal or their power factor varies from one.
<b>Positive measured power value (production) differs too much from the value on the inverter display</b>	There is connected some load, which decreases this value.	No defect
	Inverter shows approximate values, or the status is not stable	No defect
	Incorrect phase sequence or incorrect current orientation settings	Follow the steps specified in the previous item.
<b>Low tariff signal is missing</b>	Low tariff signal is not connected	Connect the low tariff signal to LT terminal. You must connect the signal through an auxiliary relay as specified in this manual.
	Low tariff signal is not active	Wait until the signal is active, or manually test the auxiliary relay by switching it on (some relays have this option).
	Regulator failure/defect	Replace the regulator or take it to repair.
<b>FB input does not work</b>	Output with open collector is connected in reverse polarity	Observe polarity of the device output (energy meter, inverter).
	Signal coming from the output is an unsupported impulse signal	Use only device with impulse output whose signal carries information about the measured energy and has a minimum impulse width of 1 ms. Signal parameters are described in chapter Technical specifications.
	Regulator failure/defect	Replace the regulator or take it to repair.
<b>The TEST button cannot be used to switch on some of the connected loads</b>	The relevant load is not connected or it is connected incorrectly	Check the connection of the relevant load and switch on the corresponding circuit breaker or fuse switch.

	The load is connected correctly but cannot be switched on	Check whether the load is fitted for example with a thermal protection system or a thermostat, which is currently off.
	Wireless peripheral device is off or out of the range.	Check functions of wireless peripheral device. In case of problems with coverage of signal, use the signal repeater. Consult this problem with technical support.
	Output LED is defect or there is another regulator defect	Replace the regulator or take it to repair.
<b>Outputs do not switch on as they should</b>	Output is not activated	Activate the output by setting the relevant priority.
	PV-plant does not provide sufficient power output	Check whether there is enough surplus energy available in respective phase wire or sum of phases L1 + L2 + L3 is positive, depending on configured control mode.
	Incorrectly set priorities or connected power values	Check the priority setting of your loads and connected power settings according to their power ratings.
	Incorrect settings of some items in the Other settings tab	Check the settings in the Power offset field. Also check the CombiWATT production limit field, which should be low.
<b>You cannot load firmware, even if you try repeatedly</b>	Incorrect or corrupted *.scf file	Load only original firmware for the WATTrouter ECO device.
	Communication errors	Make sure that there are no problems with the connection of the controller to PC, or in the PC alone (viruses etc.).
	Regulator failure/defect	Replace the regulator or take it to repair.
<b>Flashing red LED</b>	The system detected error status	Follow instructions in the LED statuses chapter.
<b>When the available surplus energy is decreased, the SSR output with higher priority is switched off earlier than the relay output with lower priority</b>	This is normal	Relay outputs have always longer delay when in the process of disconnecting. In order to make sure that energy from the power grid is not drawn unnecessarily all connected SSRs with higher priority may be disconnected earlier than the relay outputs with lower priority.
<b>CombiWATT software runs even if PV-plant produces power</b>	This is normal	CombiWATT will be initiated even if during the time specified in the CombiWATT delay time field, no production is detected at any phase wire, which may occur if the PV-plant produces small amount of energy or if loads with large power consumption operate for long time and consume all available surplus energy. If you want to eliminate this behavior, increase the value in the CombiWATT delay time field.

<b>Solid state relay (SSR) does not switch on</b>	SSR is not connected correctly	Check for proper terminal connection and observe polarity of SSR anodes.
	Incompatible relay	Always use a SSR with zero cross switch and minimum DC control voltage of 4VDC.
	Regulator failure/defect	Replace the regulator or take it to repair.
	SSR failure/defect	Replace the SSR.
<b>Data in statistics don't correspond with reality</b>	This is normal	The data are indicative only; the device does not have accurate data from utility/billing meters. Furthermore, the device may be configured improperly, i.e. does not evaluate the same as your utility meter does.
<b>Statistics suddenly erased</b>	This is normal	There was a date change in the controller or power failure during writing the history into EEPROM after midnight.
<b>SC-Gateway or SC-Router module is inserted in regulator, but all Link LEDs are off</b>	Wrong polarity of the module	Remove and insert module once again based on installation manual of the module.
	Regulator or module failure/defect	Replace the module or regulator or take them to repair.
<b>Wireless peripheral can't be registered, even after longer period while connected. Window S-Connect – new station detected is not displayed.</b>	Station out of signal range	Test the wireless peripheral so it is placed temporary closer to the regulator. Once this time it is detected, there is necessary to extend signal range with signal repeater. Consult this problem with technical support.
	Station is incompatible	It is different type of wireless peripheral, which is not compatible with SC-Gateway module.
	Stations is defective	Follow the installation manual for the wireless peripheral.
	SC-Gateway module does not react	Reset the controller and wait about 1 minute. Then repeat the network registration procedure.
	SC-Gateway module failure/defective	Replace the module or take it to repair.
<b>Wireless station does not switch or switches incorrectly</b>	Station out of signal range	Test the wireless peripheral so it is placed temporary closer to the regulator. Once this time it is detected, there is necessary to extend signal range with signal repeater. Consult this problem with technical support.
	Stations is defective	Follow the station manual
	SC-Gateway module does not react	Reset the controller and wait about 1 minute. Then test the function of the peripheral.



## MAINTENANCE AND REPAIRS

The regulator and current sensing module have been designed as maintenance-free units, provided that they were configured and fitted according to instructions specified in this manual. We recommend inspecting the operation of the entire system at regular intervals (at least once in a month, for example, when inspecting the status of the PV-plant). Focus mainly on the load switching process and heat dissipation of power SSRs.

Should you discover a defect which cannot be repaired according to instructions specified in the Troubleshooting chapter, contact your distributor (applies both to warranty and post warranty repairs).

Defect on current sensing module is very unlikely to occur. In case of a defective regulator, you can send only the regulator for repair or replacement. The current sensing module may still remain fitted without the regulator. Even if electric currents flow through measuring coils, the module will not be damaged.

**Never attempt to repair your device by yourself! If you do so, you are putting yourself at risk of electric shock. Further, your entire warranty will be void!**

## TECHNICAL SPECIFICATIONS

Parameter	Value, notes
<b>Main parameters</b>	
Supply voltage	230 V~, 50 Hz
Power consumption – stand-by mode	<3 VA
Power consumption – 1 relay output	0.4 W
Power consumption – all outputs switched on and loaded with maximum allowable currents	4 W (this value does not include the switching losses of power SSRs)
Current measuring range	0-20 A~ (±5 %), 50 Hz (±5 %)
Voltage range	230V~ (±5%), 50Hz (±5%)
Maximum steady currents allowed to flow through current sensing module	0-40 A~ (±5 %), 50 Hz (±5 %)
Active power measuring accuracy	5% ± 0,05kW
<b>Output and input parameters</b>	
L1 input	230 V~, 50 Hz
I_L1, I_L2, I_L3 inputs:	Secondary currents from measuring coils. Maximum allowed voltage against GND terminal is 5.5 V.
Relay outputs	230 V~, 50 Hz, max. 10 A, 2300 W (it is recommended to connect load with $\cos(\Phi) \neq 1$ via external contactor) Protection: Regular circuit breaker, type B
External outputs for connection of solid state relays SSR (S+, S1-, S2-,S3-,S4-)	0 or 5 VDC, isolated from power grid supply SSR parameters: control DC min. 4VDC, SSR must switch at zero (zero switch). Protection: based on instructions specified in the SSR relay manual
External outputs - connection with PWM function SSR (S+, S1-, S2-,S3-,S4-)	0 or 5 VDC, isolated from power grid supply PWM parameters: carrier frequency 200 Hz, duty cycle 0-100% in 1% steps. Protection: based on instructions specified in the manual of connected device
LT, FB inputs	0 or 5 VDC, isolated from power grid supply May be switched using regular relay outputs or optocouplers with open collector, always against GND. Minimum pulse width and gaps for FB inputs is 1ms.
USB Connection	USB 1.1/ USB 2.0, isolated both from power grid supply and additionally optically isolated
<b>Dynamic characteristics</b>	
Active power measuring period (effective values)	typically 600 ms (including averaging of switched-on SSRs)
Regulation dynamics (full scale) at SSR output	typically 3 s (from 0 to 100 % of power output and vice versa)
Relay output on-delay time	Programmable (minimum of 2s)

Relay output off-delay time	Programmable (minimum of 2s)
<b>Other parameters</b>	
Maximum diameter of wires connected to terminals	2.5 mm
Maximum diameter of wires passing through measuring transformers	9 mm (including insulation)
Distance of the current sensing module and the regulator	<2 m (longer wires are acceptable, but they reduce the accuracy approx. by 0.2% per 2m).
Distance of the regulator and solid state relay	<10 m
Working position	any
Mounting	Regulator: DIN 35mm or wall mounted using 2 screws with round or sink head and with diameter of up to 6mm. Current sensing module: DIN 35mm or wall mounted using 1 screw with round or sink head and with diameter of up to 6mm.
Overvoltage category	III
Electric strength	4 kV / 1 min (power supply (L, N)-output, output - output, power supply-current input, external output, etc.(GND,I_L...,LT,FB...,S+,S1- ,S2- ,S3- , S4-))
Pollution degree	2
Operational temperature range	-20°C to +40°C
Storage temperature range	-40 °C to +80 °C
Protection (power supply)	B6A
IP code	Regulator and current sensing module: IP 20
Dimensions (WxHxD)	Regulator: 70x110x64mm (4 modules) Current sensing module: 70x110x64mm (4 modules)
Weight	Regulator: 350g current sensing module: 100g
Noise level (including SSR)	Only passive cooling, for power SSR is necessary to ensure sufficient heat dissipation.
Battery for real time backup	CR2032 lithium, usual lifetime> 6 years
Warranty period	24 months

## BATTERY FOR REAL TIME BACKUP

The regulator contains a CR2032 type battery for real time backup. If the controller shows an incorrect date and time after a power failure, then the battery is discharged. The battery can be replaced.

The battery can be of two types (the battery type can be determined by opening the lid of the regulator with a small screwdriver):

- a) Soldered battery to the regulator PCB. This battery usually has a yellow band around the perimeter and contacts for soldering. To replace this battery, it is necessary to disassemble the device and entrust the replacement to an electronics repair service.
- b) Standard battery placed in a case. This battery can be replaced by yourself without having to disassemble the device. Remove the battery with a suitable tool, for example a plastic clamp, after removing the regulator lid. Insert the spare battery in the same way.

**Important notice:** *It is absolutely necessary to respect the polarity of the battery. If you insert the battery the other way round, the main microprocessor will be damaged! When replacing the battery, do not use metal tools that could short-circuit the battery!*

## RECYCLING

After the product life is over the product may be disassembled, recycled or disposed of at a save dumpsite.

Legal regulations regarding electronic waste treatment have to be observed in respective country.

Before product disposal, remove real time backup battery (if possible).

Do not dispose in regular household waste!

## DECLARATION OF CONFORMITY



Company:

**SOLAR controls s.r.o.** (manufacturer name)  
**Brojova 25, Plzeň, 32600, Czech Republic**(manufacturer address)  
**29109795** (manufacturer id)

Hereby declares that this product:

**WATTrouter ECO** (product name)  
**WRE 01/06/14 (regulator) and WT 02/10 (current sensing modules)** (type/model)  
**Designed for to optimize self-consumption of electric power produced by photovoltaic power plant** (function)

To which this declaration relates is in conformity with the following directives, standards and other normative documents, provided that it is installed, maintained and used in application for which it was made, in accordance with relevant installation standards and manufacturer's instructions:

Directives:

- LVD Directive 2006/95 EC
- EMC Directive 2004/108 EC

Standards:

- EN 61010-1:2010
- EN 61000-3-2:2006+A1:08+A2:09
- EN 61000-3-3:2008
- EN 61000-3-11:2000
- EN 61000-4-2:2009
- EN 61000-4-4:2012
- EN 61000-4-5:2006
- EN 61000-4-11:2004
- EN 61000-6-3:2007

Year of affixing the CE marking: 2014

Declaration issued:

**Plzeň, October 1, 2014**

(place and date)

**Ing. Tomáš Krýsl, Company Executive**

(name, job title and signature of responsible person of the manufacturer)

 **solar** S.R.O. **CONTROLS**  
ELEKTRONICKÉ A DIAGNOSTICKÉ SYSTÉMY  
Brojova 2053/25, PLZEŇ, CZ 326 00  
IČ: 29109795 DIČ: CZ29109795  
Tel: +420 724 543 601 [www.solarcontrols.cz](http://www.solarcontrols.cz)